

Mur Vario 4S (625)

Fiche de production

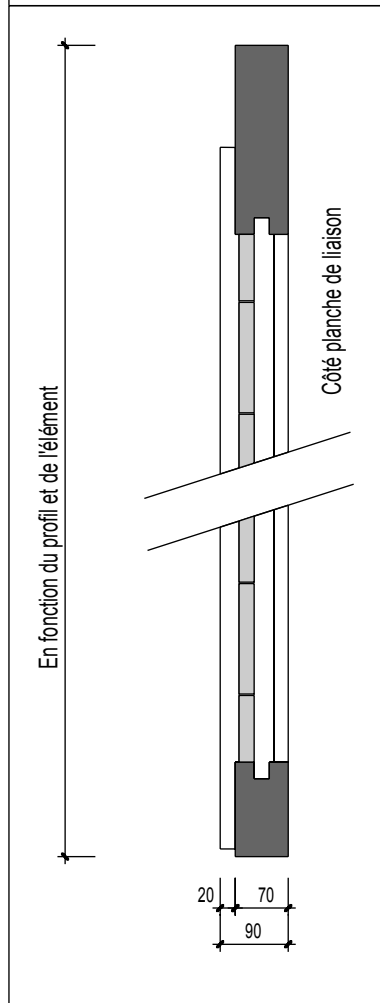
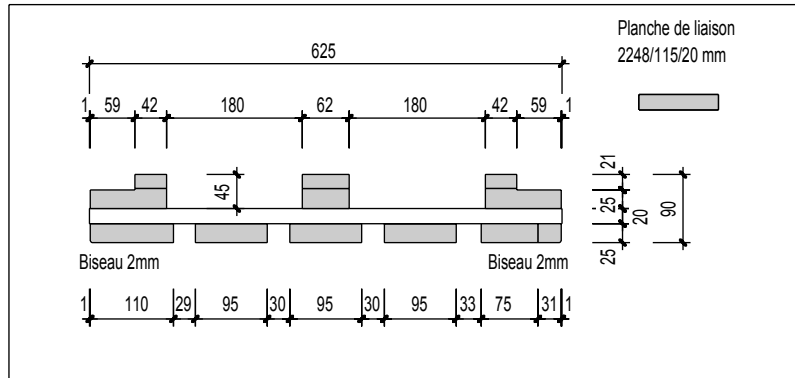
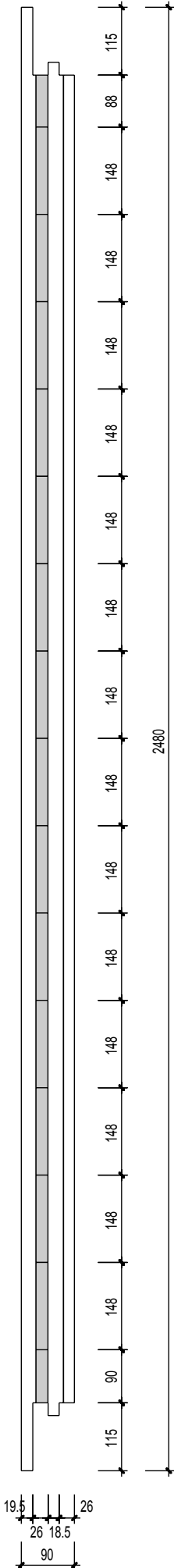

LIGNOTREND Profil

Lisse avec rainure simple ou double

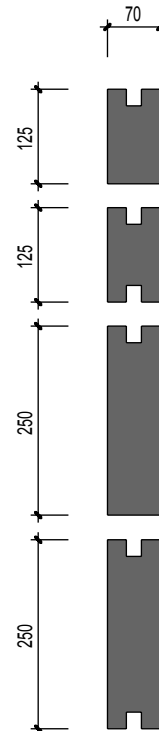

LIGNOTREND Produktions GmbH
Landstrasse 25 D-79809 Weilheim-Bannholz
Tel : 07755-9200 0 Fax : 07755-9200 55

LIGNO TREND®
Ainsi construit notre génération.

Projet	LIGNOTREND						
Plan-Nr.	Mur Vario 4S 625 mm						
	01-2 Coupe de principe						
erstellt	gedruckt	Größe	Maßstab	gezeichnet	geändert	geändert	gesehen
04-04-2006	11-03-2008	A4	1:10	A.F.			
Murs 2008.2d							

Mur Fux 4S (500/750)

Fiche de production

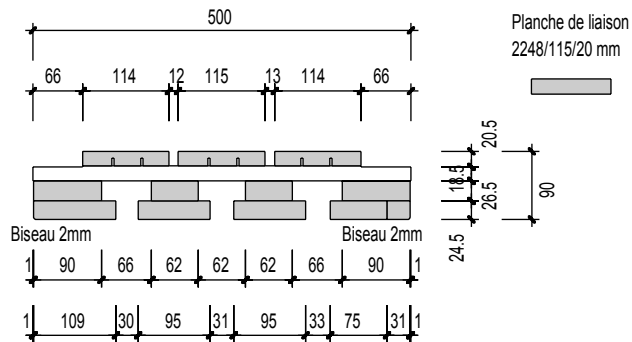
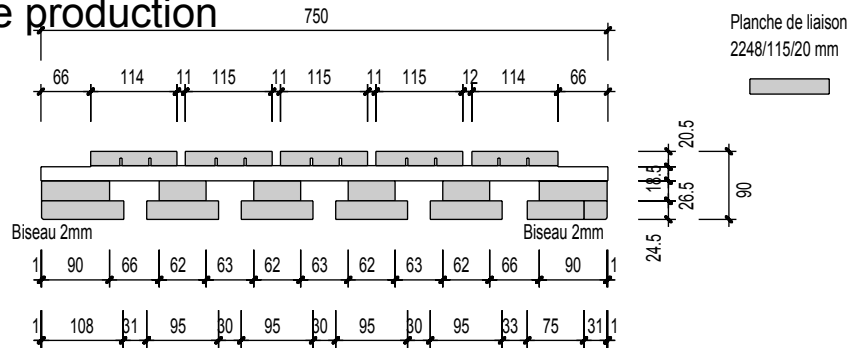

2480

En fonction du profil et de l'élément

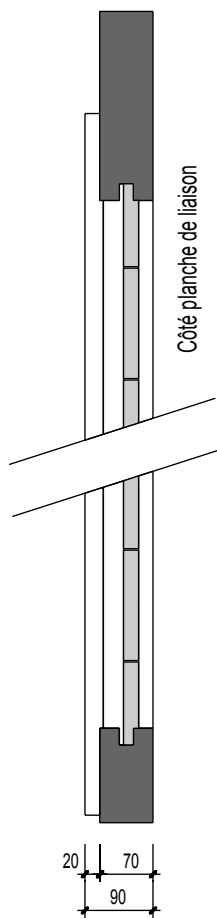

LIGNOTREND Profil

Lisse avec rainure simple ou double

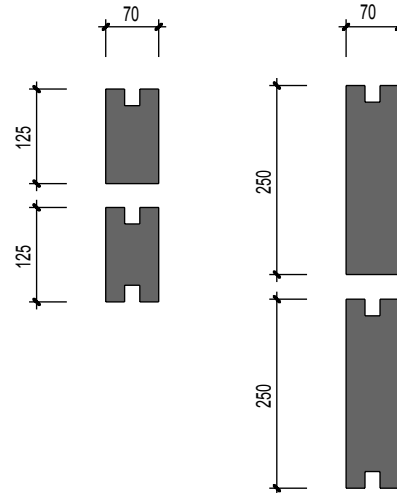

LIGNOTREND Produktions GmbH
Landstrasse 25 D-79809 Weilheim-Bannholz
Tel : 07755-9200 0 Fax : 07755-9200 55

LIGNO TREND[®]
Ainsi construit notre génération.

Projet	LIGNOTREND						
Plan-Nr.	Mur Fux 4S 500/750 mm						
	02-5 Coupe de principe						
erstellt	gedruckt	Größe	Maßstab	gezeichnet	geändert	geändert	gesehen
04-04-2006	11-03-2008	A4	1:10	A.F.			
Murs 2008.2d							

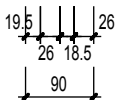

Mur Lux 5 (625)

Fiche de production



Planche de liaison
2248/115/20 mm



LIGNOTREND Profil

Lisse avec rainure
simple ou double

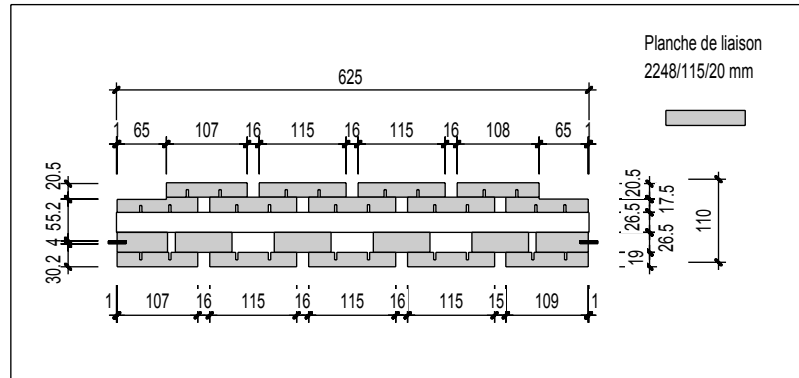
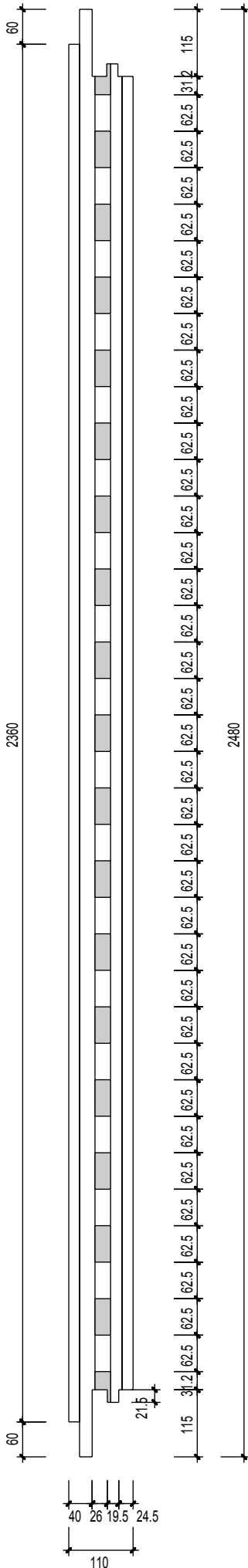
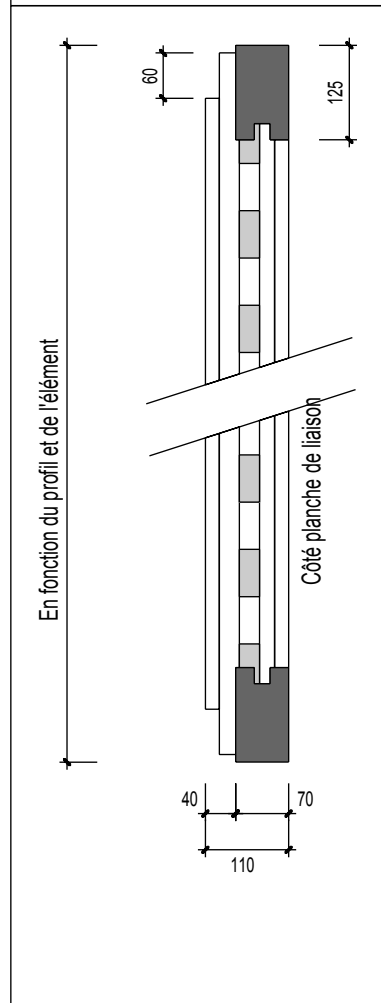
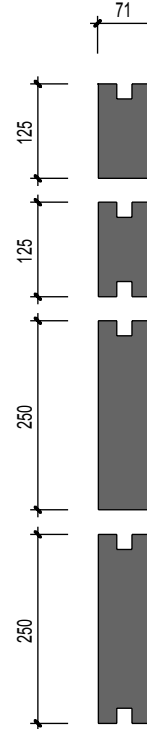

LIGNOTREND Produktions GmbH
Landstrasse 25 D-79809 Weilheim-Bannholz
Tel : 07755-9200 0 Fax : 07755-9200 55

LIGNO TREND[®]
Ainsi construit notre génération.

Projet	LIGNOTREND						
Plan-Nr.	Mur Lux 5 625 mm						
	03-2 Coupe de principe						
erstellt	gedruckt	Größe	Maßstab	gezeichnet	geändert	geändert	gesehen
04-04-2006	11-03-2008	A4	1:10	A.F.			
Murs 2008.2d							

Dalle D Q3 Standard

Dalle D Q3 Joint creux de 3mm

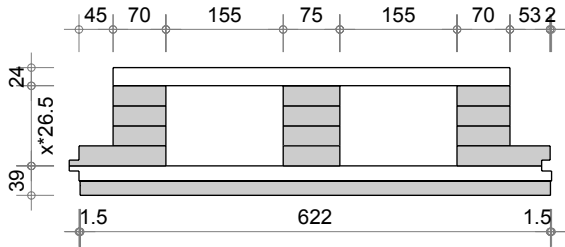

Dalle D Q3 Joint V de 7,9mm

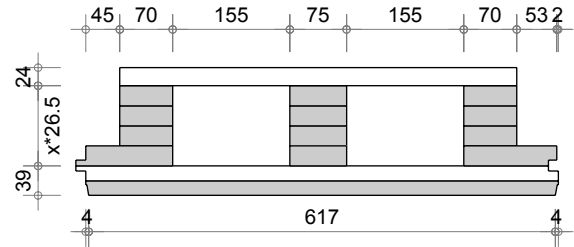

Dalle D Q3 alpha (625-12-4, P.: 12mm)

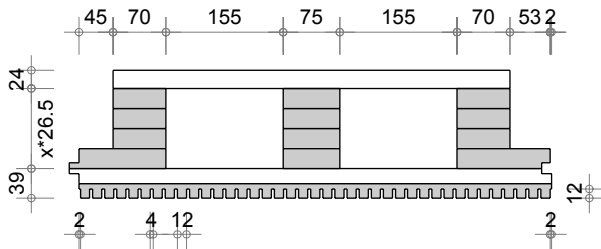

Dalle D Q3 alpha (625-25-8, P.: 12mm)

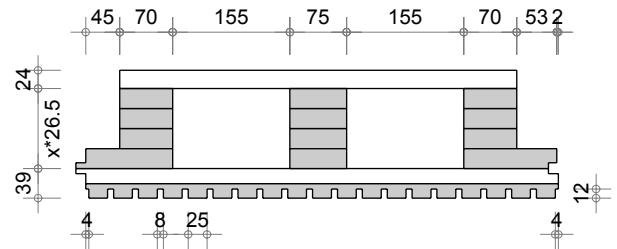

Dalle D Q3 pièce de liaison

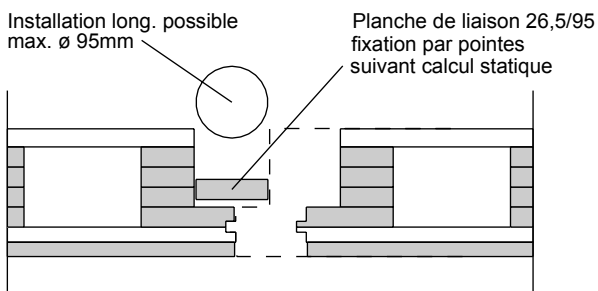

Dalle D Q3 coupe long.

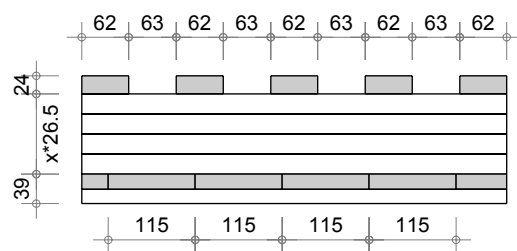

LIGNOTREND Produktions GmbH Landstrasse 25 D-79809 Weilheim-Bannholz Tel : 07755-9200 0 Fax : 07755-9200 55		LIGNO TREND® <small>Ainsi construit notre génération.</small>			
Projet		LIGNOTREND			
Plan-Nr. 02-01-20		Dalle D Q3 Standard			
erstellt	Größe	Maßstab	geändert	geändert	geändert
01-01-2008 / AF	A4	1:10			
Dalle D Q3 2008.2d					

Dalle D Q3 Z1

Dalle D Q3 Z1 Joint creux de 3mm

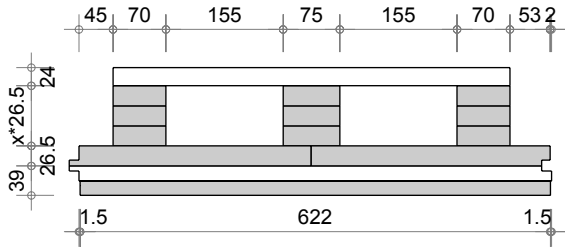

Dalle D Q3 Z1 Joint V de 7,9mm

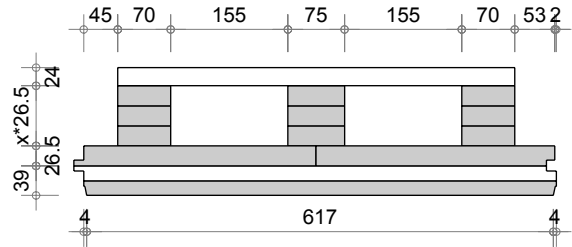

Dalle D Q3 alpha Z1 (625-12-4, P.: 12mm)

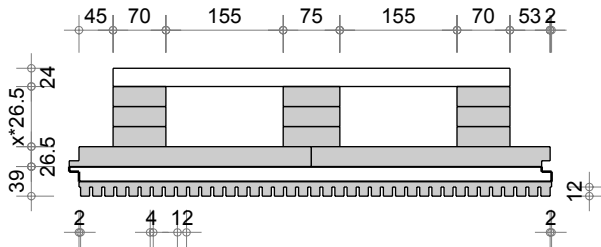

Dalle D Q3 alpha Z1 (625-25-8, P.: 12mm)

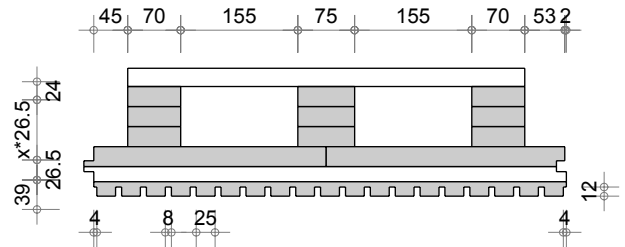

Dalle D Q3 Acoustique alpha Z1 (625-12-4)

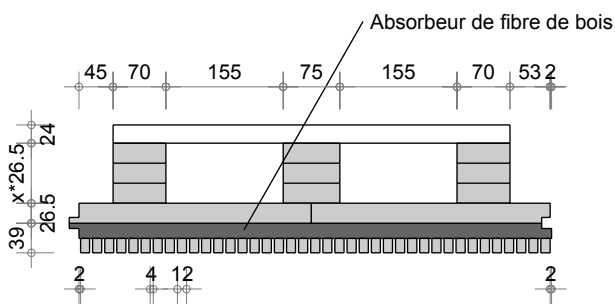

Dalle D Q3 Acoustique alpha Z1 (625-25-8)

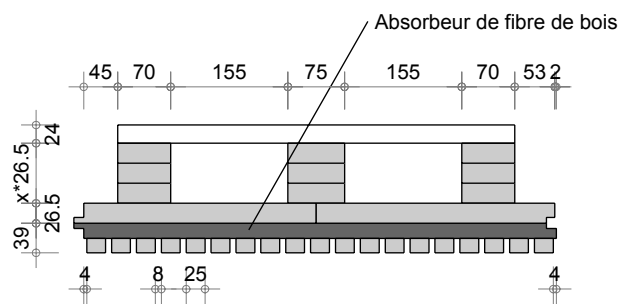

Dalle D Q3 Acoustique coupe long.

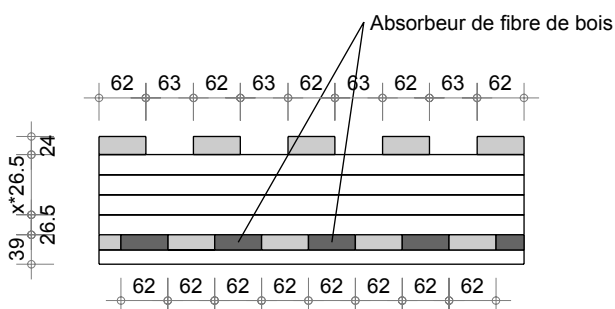

LIGNOTREND Productions GmbH Landstrasse 25 D-79809 Weilheim-Bannholz Tel : 07755-9200 0 Fax : 07755-9200 55		LIGNO TREND® <small>Ainsi construit notre génération.</small>			
Projet		LIGNOTREND			
Plan-Nr. 02-01-21		Dalle D Q3 Z1			
erstellt	Größe	Maßstab	geändert	geändert	geändert
01-01-2008 / AF	A4	1:10			
Dalle D Q3 2008.2d					

Dalle D Q3 coupe de principe

Dalle D Q3 143

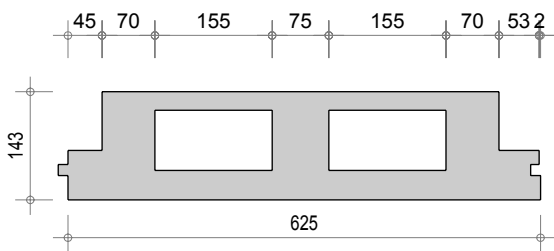

Dalle D Q3 169

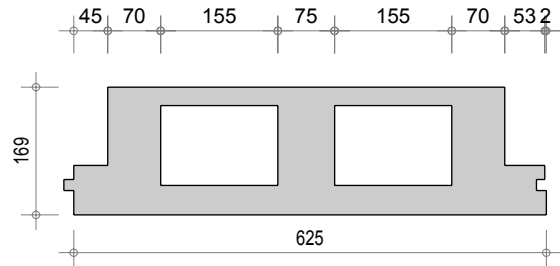

Dalle D Q3 196

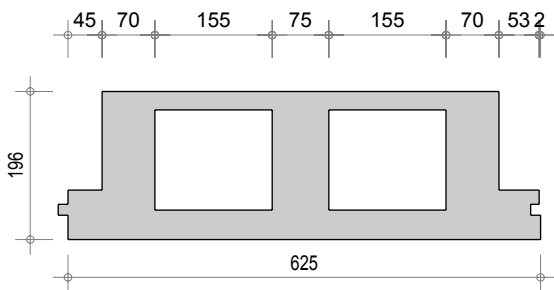

Dalle D Q3 222

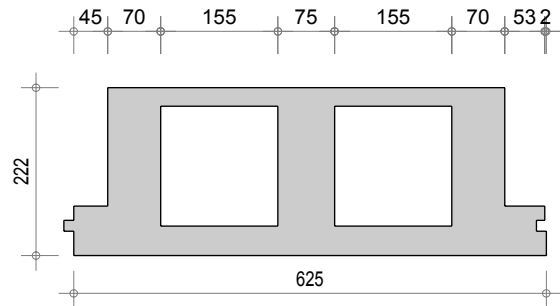

Dalle D Q3 249

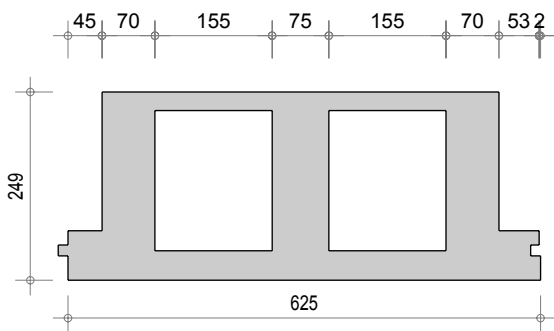

Dalle D Q3 275

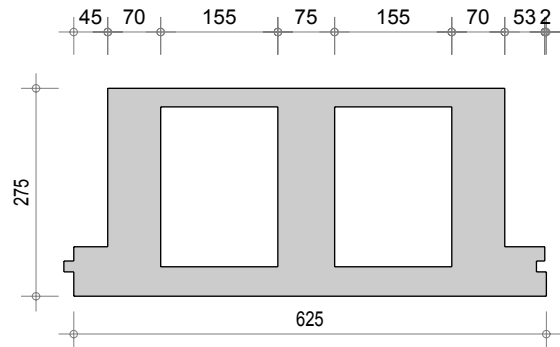

LIGNOTREND Produktions GmbH
Landstrasse 25 D-79809 Weilheim-Bannholz
Tel : 07755-9200 0 Fax : 07755-9200 55

LIGNO TREND®
Ainsi construit notre génération.

Projet LIGNOTREND

Plan-Nr. Dalle D Q3
02-01-22 Coupe de principe

erstellt	Größe	Maßstab	geändert	geändert	geändert
01-01-2008 / AF	A4	1:10			

Dalle D Q3 2008.2d

Dalle D Q4 Standard

Dalle D Q4 Joint creux de 3mm

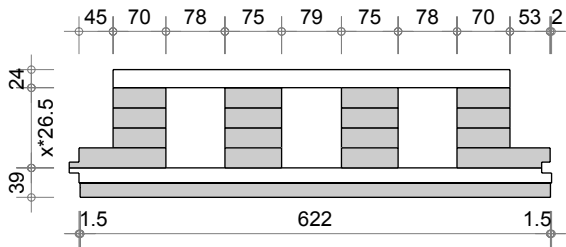

Dalle D Q4 Joint V de 7,9mm

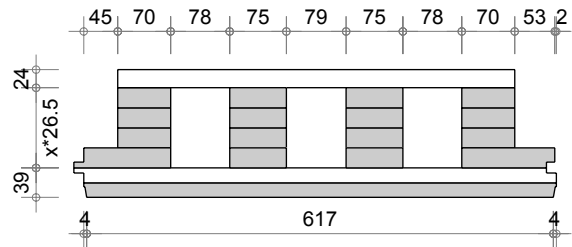

Dalle D Q4 alpha (625-12-4, P.: 12mm)

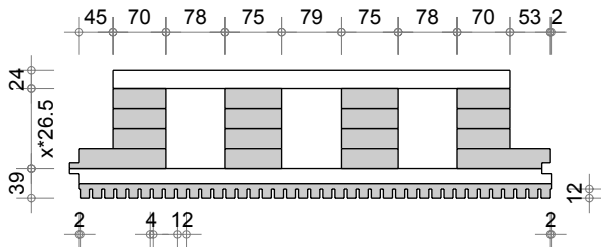

Dalle D Q4 alpha (625-25-8, P.: 12mm)

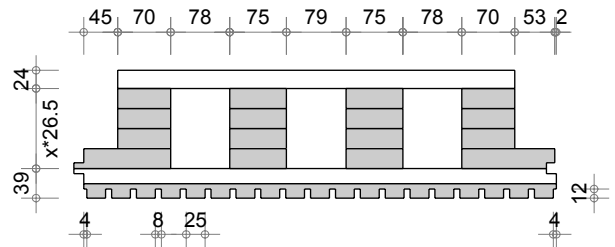

Dalle D Q4 pièce de liaison

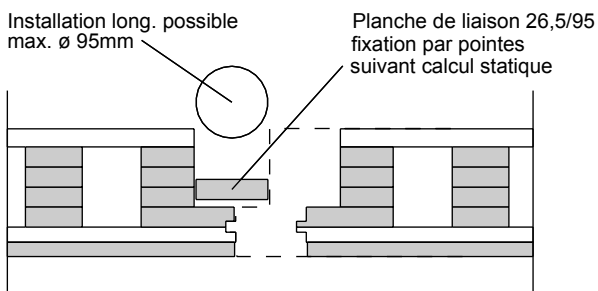

Dalle D Q4 coupe de long.

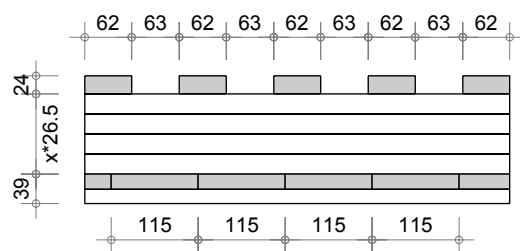

LIGNOTREND Produktions GmbH
Landstrasse 25 D-79809 Weilheim-Bannholz
Tel : 07755-9200 0 Fax : 07755-9200 55

LIGNO TREND®
Ainsi construit notre génération.

Projet	LIGNOTREND				
Plan-Nr.	Dalle D Q4 Standard				
02-02-20					
erstellt	Größe	Maßstab	geändert	geändert	geändert
01-01-2008 / AF	A4	1:10			
Dalle D Q4 2008.2d					

Dalle D Q4 Z1

Dalle D Q4 Z1 Joint creux de 3mm

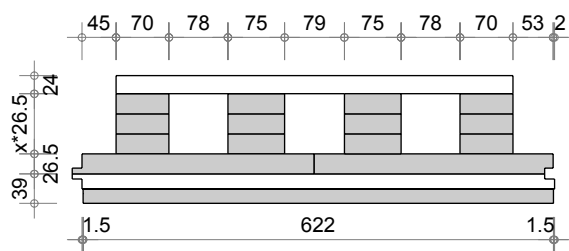

Dalle D Q4 Z1 Joint V de 7,9mm

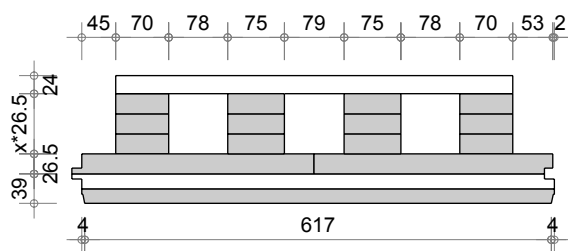

Dalle D Q4 alpha Z1 (625-12-4, P.: 12mm)

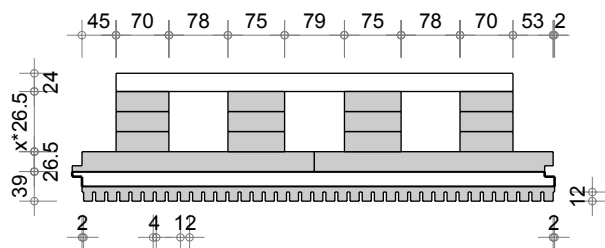

Dalle D Q4 alpha Z1 (625-25-8, P.: 12mm)

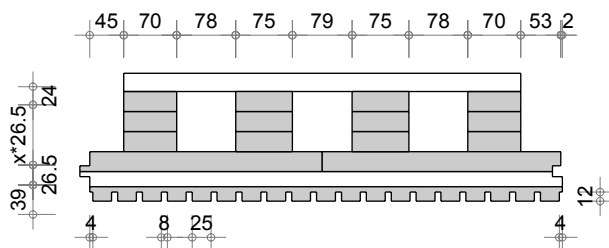

Dalle D Q4 Acoustique alpha Z1 (625-12-4)

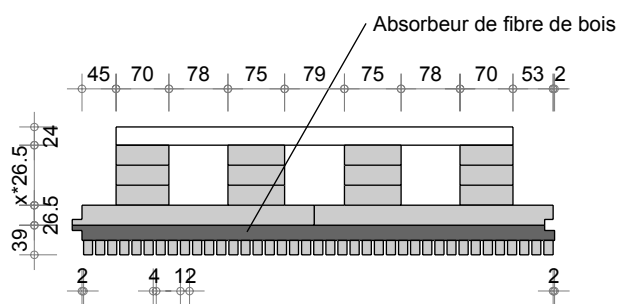

Dalle D Q4 Acoustique alpha Z1 (625-25-8)

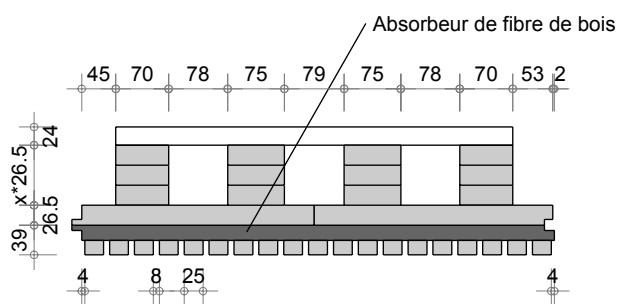

Dalle D Q4 Acoustique coupe long.

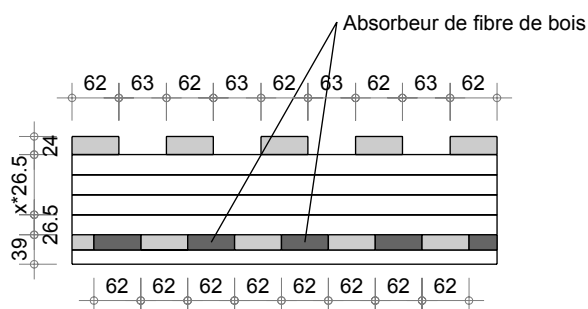

LIGNOTREND Productions GmbH Landstrasse 25 D-79809 Weilheim-Bannholz Tel : 07755-9200 0 Fax : 07755-9200 55		LIGNO TREND® <small>Ainsi construit notre génération.</small>			
Projet	LIGNOTREND				
Plan-Nr. 02-02-21	Dalle D Q4 Z1				
erstellt	Größe	Maßstab	geändert	geändert	geändert
01-01-2008 / AF	A4	1:10			
Dalle D Q4 2008.2d					

Dalle D Q4 coupe de principe

Dalle D Q4 143

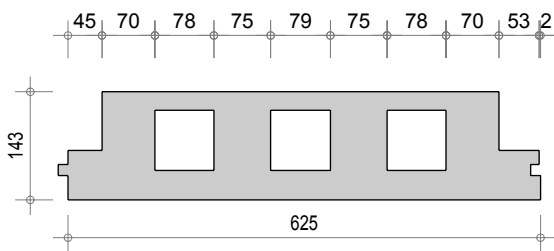

Dalle D Q4 169

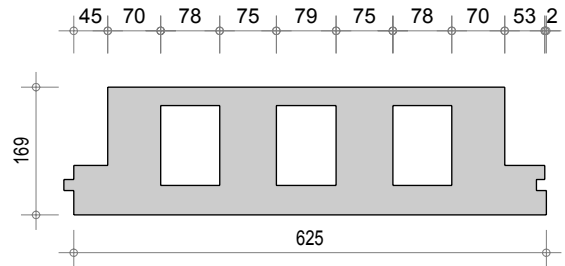

Dalle D Q4 196

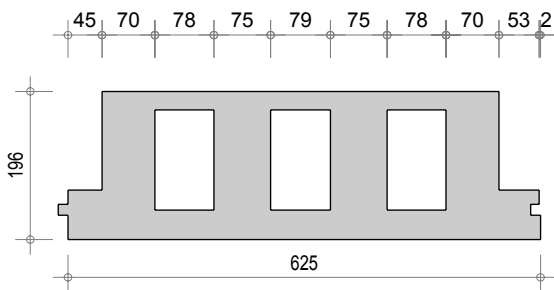

Dalle D Q4 222

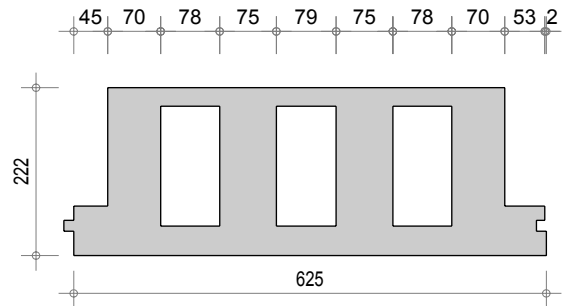

Dalle D Q4 249

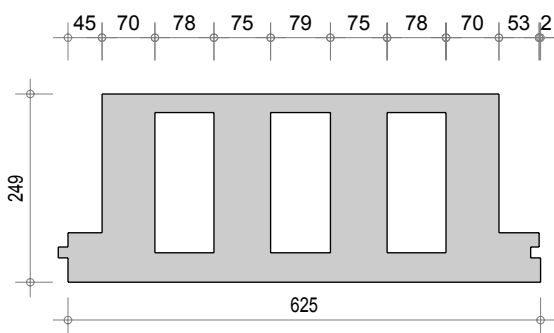

Dalle D Q4 275

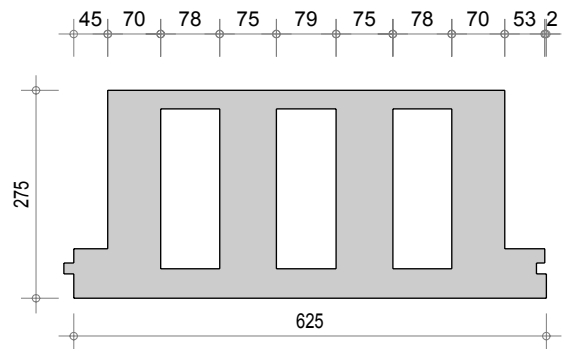

LIGNOTREND Produktions GmbH
Landstrasse 25 D-79809 Weilheim-Bannholz
Tel : 07755-9200 0 Fax : 07755-9200 55

LIGNO TREND®
Ainsi construit notre génération.

Projet LIGNOTREND

Plan-Nr. Dalle D Q4
02-02-22 Coupe de principe

erstellt	Größe	Maßstab	geändert	geändert	geändert
01-01-2008 / AF	A4	1:10			

Dalle D Q4 2008.2d

Dalle R Q3 Standard

Dalle R Q3 Joint creux de 3mm

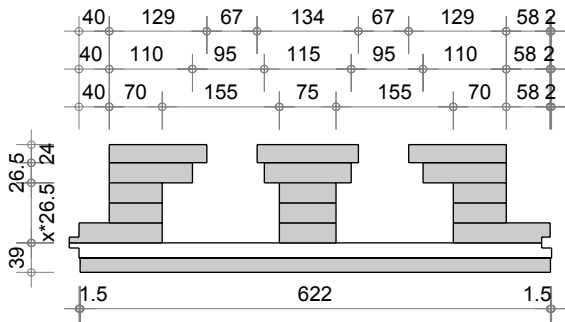

Dalle R Q3 Joint V de 7,9mm

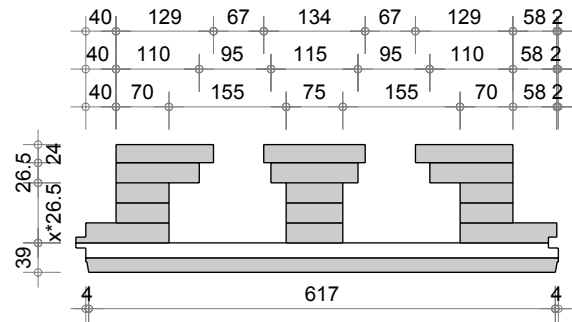

Dalle R Q3 alpha (625-12-4, P.: 12mm)

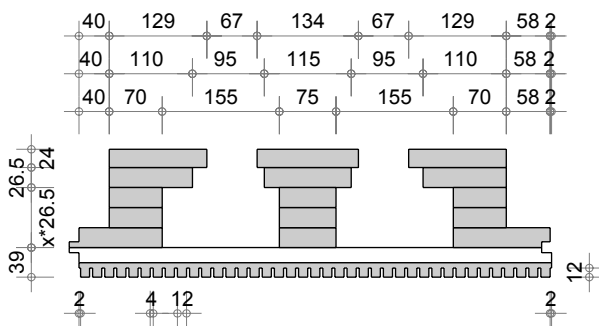

Dalle R Q3 alpha (625-25-8, P.: 12mm)

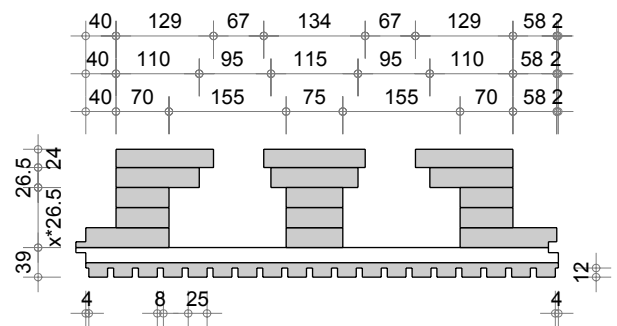

Dalle R Q3 pièce de liaison

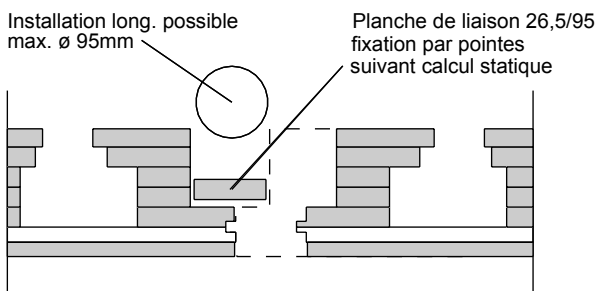

Dalle R Q3 coupe long.



LIGNOTREND Produktions GmbH Landstrasse 25 D-79809 Weilheim-Bannholz Tel : 07755-9200 0 Fax : 07755-9200 55		LIGNO TREND® <small>Ainsi construit notre génération.</small>			
Projet	LIGNOTREND				
Plan-Nr. 04-01-20	Dalle R Q3 Standard				
erstellt	Größe	Maßstab	geändert	geändert	geändert
01-01-2008 / AF	A4	1:10			
Dalle R Q3 2008.2d					

Dalle R Q3 Z1

Dalle R Q3 Z1 Joint creux de 3mm

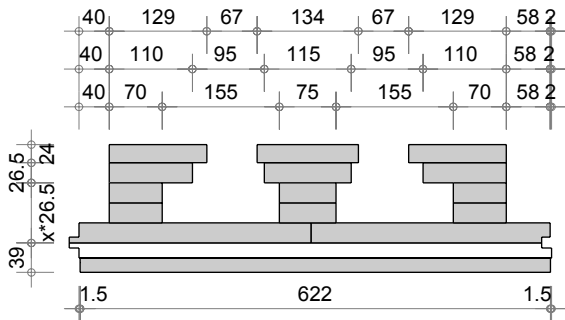

Dalle R Q3 Z1 Joint V de 7,9mm

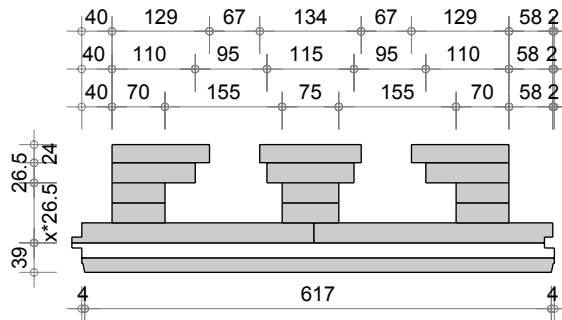

Dalle R Q3 alpha Z1 (625-12-4, P.: 12mm)

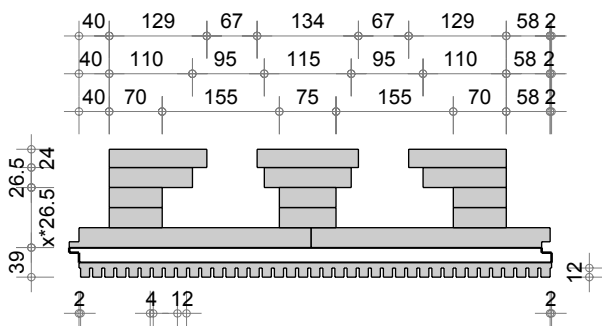

Dalle R Q3 alpha Z1 (625-25-8, P.: 12mm)

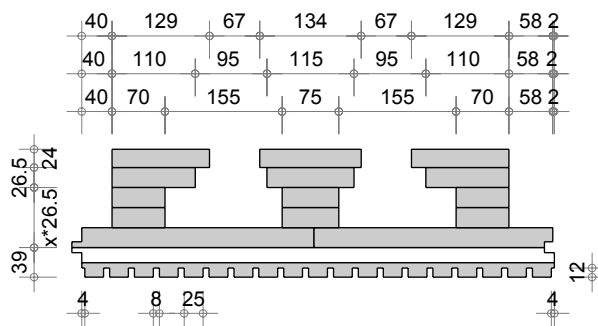

Dalle R Q3 Acoustique alpha Z1 (625-12-4)

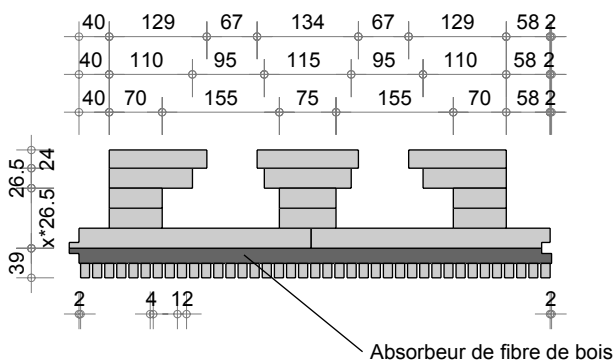

Dalle R Q3 Acoustique alpha Z1 (625-25-8)

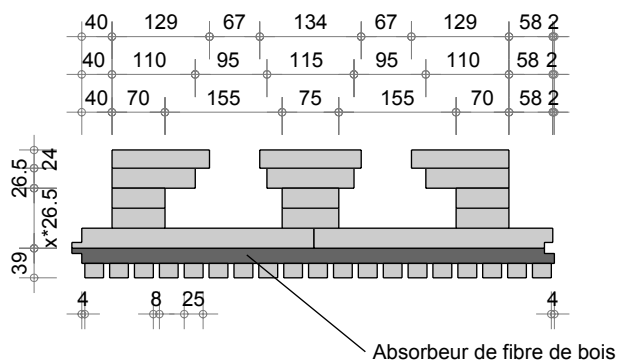

Dalle R Q3 Acoustique coupe long.

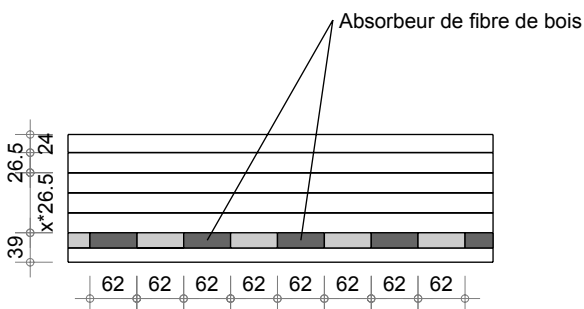

LIGNOTREND Productions GmbH Landstrasse 25 D-79809 Weilheim-Bannholz Tel : 07755-9200 0 Fax : 07755-9200 55		LIGNO TREND® Ainsi construit notre génération.	
Projet	LIGNOTREND		
Plan-Nr.	Dalle R Q3		
04-01-21	Z1		
erstellt	Größe	Maßstab	geändert
01-01-2008 / AF	A4	1:10	
Dalle R Q3 2008.2d			

Dalle R Q3 coupe de principe

Dalle R Q3 116

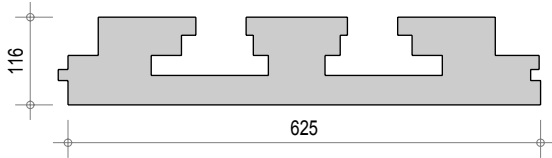

Dalle R Q3 143

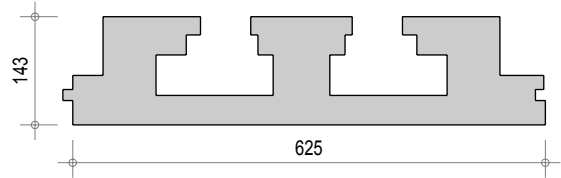

Dalle R Q3 169

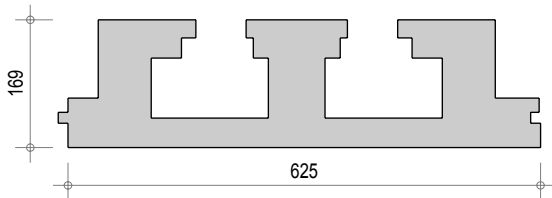

Dalle R Q3 196

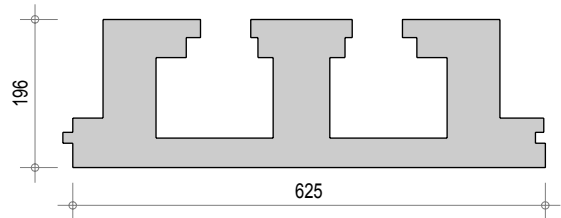

Dalle R Q3 222

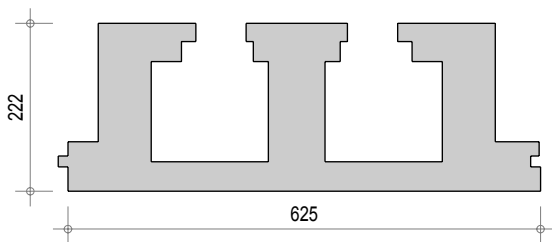

Dalle R Q3 249

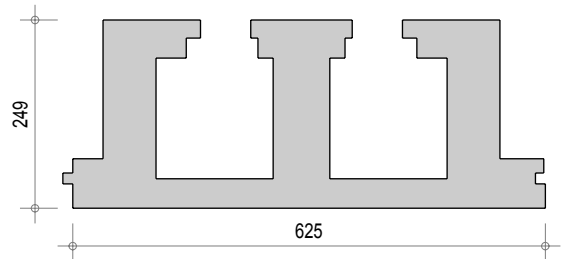

Dalle R Q3 275

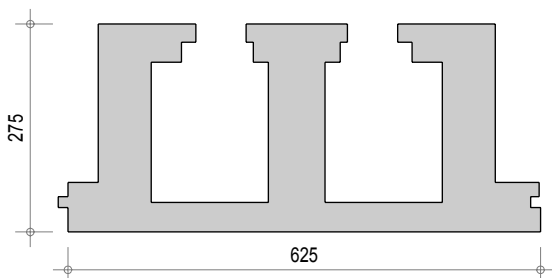

LIGNOTREND Produktions GmbH
Landstrasse 25 D-79809 Weilheim-Bannholz
Tel : 07755-9200 0 Fax : 07755-9200 55

LIGNO ■ TREND®
Ainsi construit notre génération.

Projet LIGNOTREND

Plan-Nr. Dalle R Q3
04-01-22 Coupe de principe

erstellt	Größe	Maßstab	geändert	geändert	geändert
01-01-2008 / AF	A4	1:10			

Dalle R Q3 2008.2d

Dalle R Q3 BV Standard

Dalle R Q3 BV Joint creux de 3mm

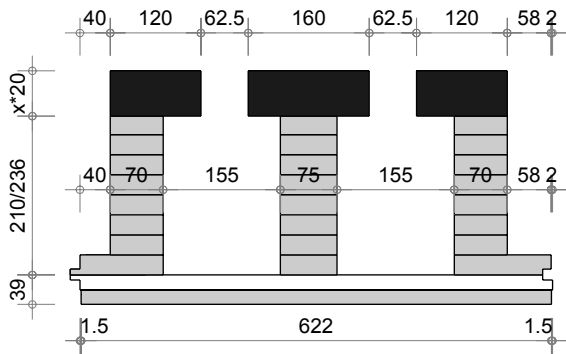

Dalle R Q3 BV Joint V de 7,9mm

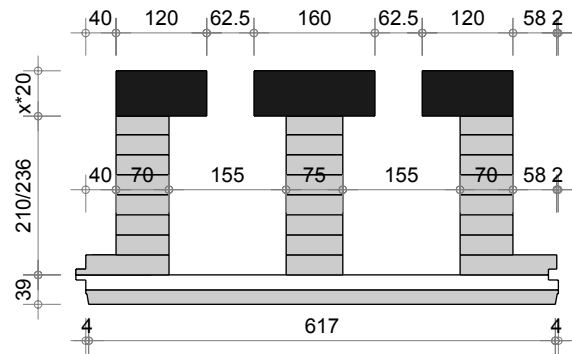

Dalle R Q3 alpha BV (625-12-4, P.: 12mm)

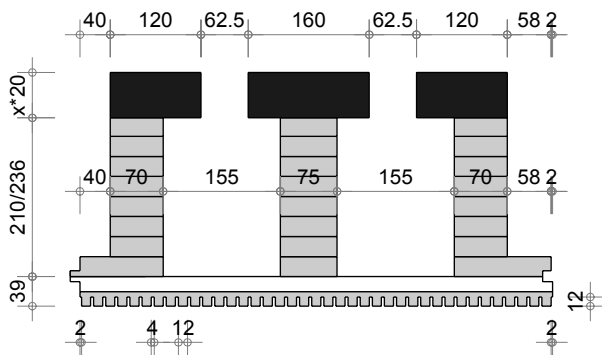

Dalle R Q3 alpha BV (625-25-8, P.: 12mm)

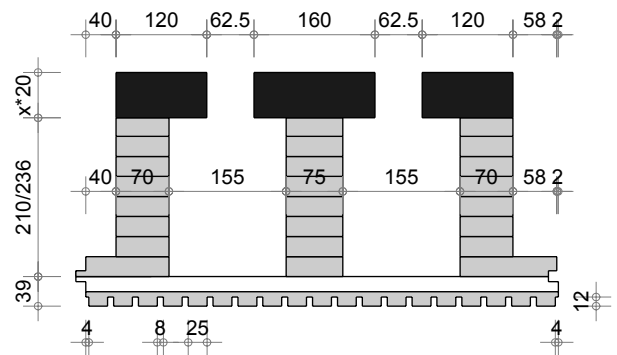

Dalle R Q3 BV pièce de liaison

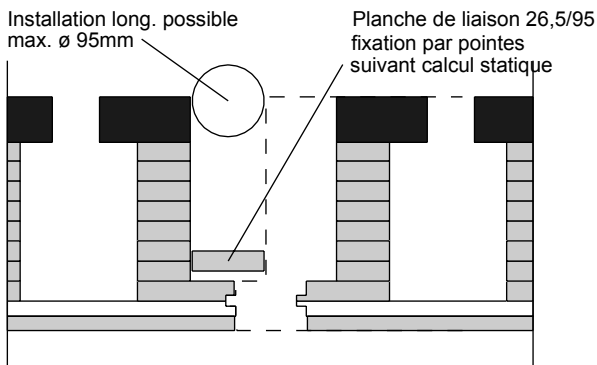

Dalle R Q3 BV coupe long.

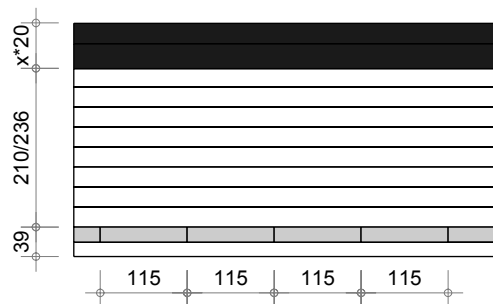

LIGNOTREND Produktions GmbH
Landstrasse 25 D-79809 Weilheim-Bannholz
Tel : 07755-9200 0 Fax : 07755-9200 55

LIGNO TREND®
Ainsi construit notre génération.

Projet LIGNOTREND

Plan-Nr. 02-02-20
Dalle R Q3 BV Standard

erstellt	Größe	Maßstab	geändert	geändert	geändert
01-01-2008 / AF	A4	1:10			

Dalle R Q3 BV 2008.2d

Dalle R Q3 Z1 BV

Dalle R Q3 Z1 BV Joint creux de 3mm

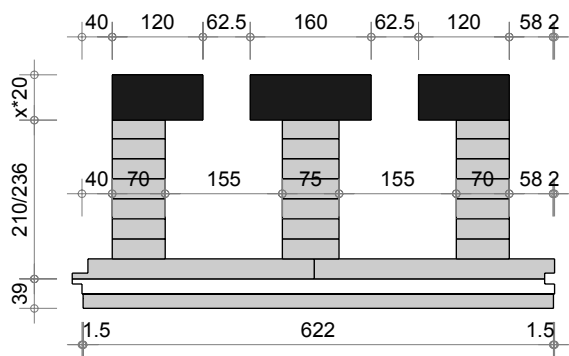

Dalle R Q3 Z1 BV Joint V de 7,9mm

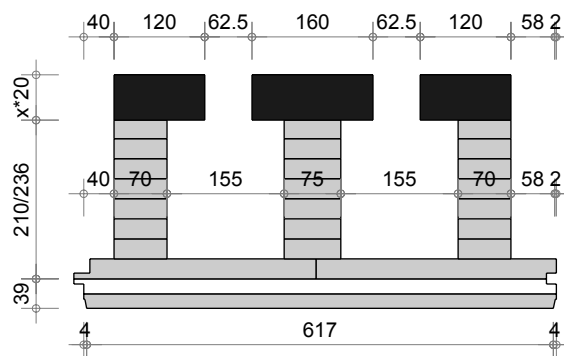

Dalle R Q3 alpha Z1 BV (625-12-4,P.: 12mm)

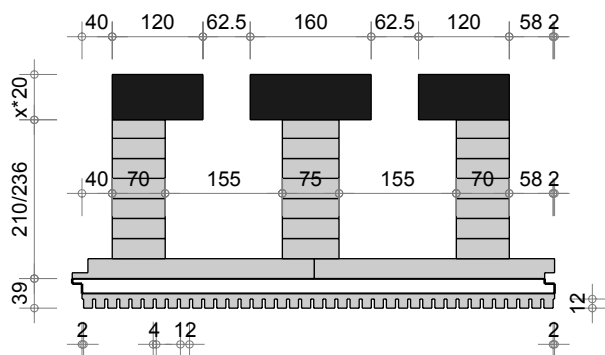

Dalle R Q3 alpha Z1 BV (625-25-8,P: 12mm)

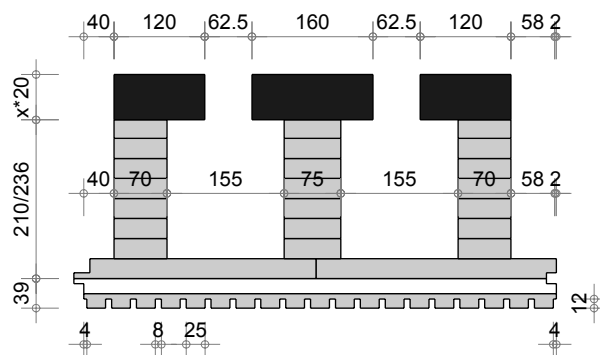

Dalle R Q3 Ac. alpha Z1 BV (625-12-4)

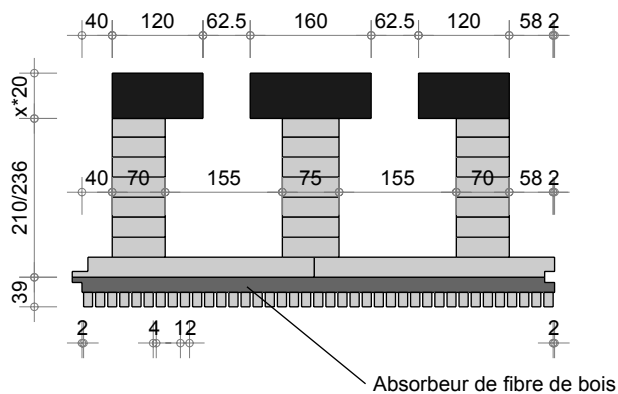

Dalle R Q3 Ac. alpha Z1 BV (625-25-8)

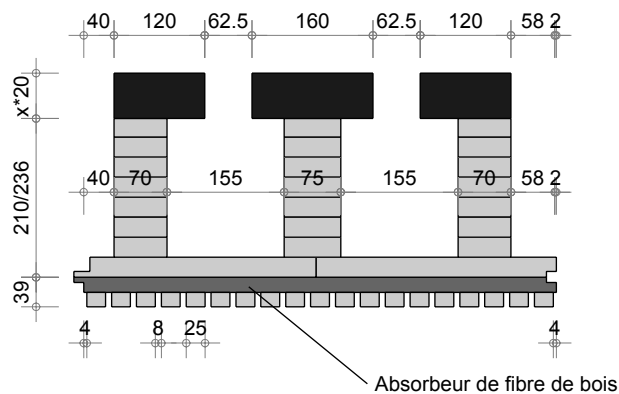

Dalle R Q3 Acoustique BV coupe long.

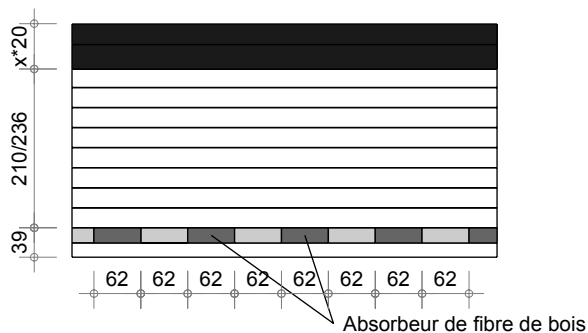

LIGNOTREND Produktions GmbH
Landstrasse 25 D-79809 Weilheim-Bannholz
Tel : 07755-9200 0 Fax : 07755-9200 55

LIGNO TREND®
Ainsi construit notre génération.

Projet LIGNOTREND

Plan-Nr. Dalle R Q3 BV
02-02-21 Z1

erstellt	Größe	Maßstab	geändert	geändert	geändert
01-01-2008 / AF	A4	1:10			

Dalle R Q3 BV 2008.2d

Dalle R Q3 BV coupe de principe

Dalle R Q3 BV 309

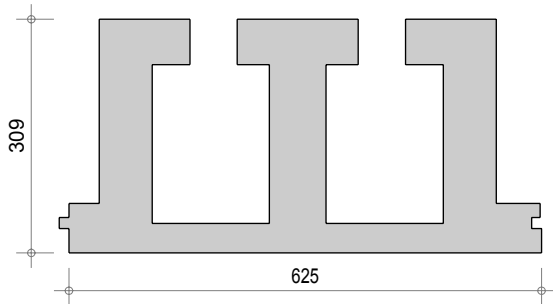

Dalle R Q3 BV 335

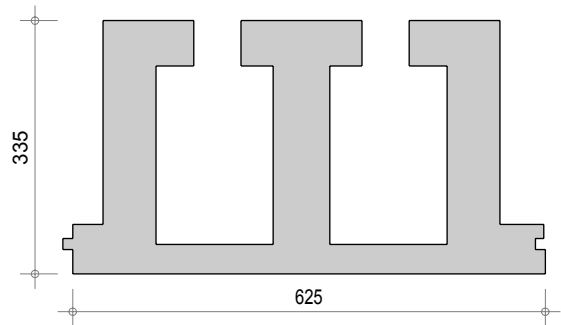

Dalle R Q3 BV 355

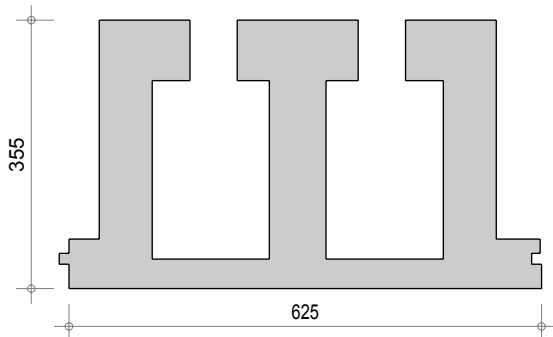

Dalle R Q3 BV 375

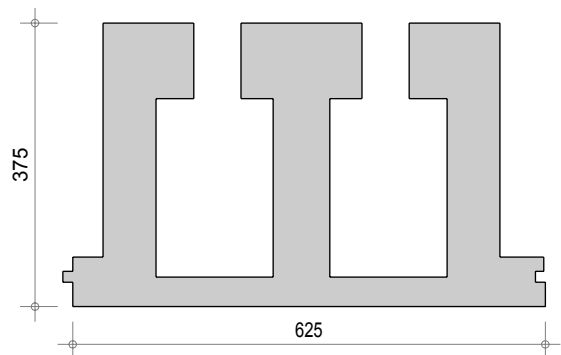

Dalle R Q3 BV 395

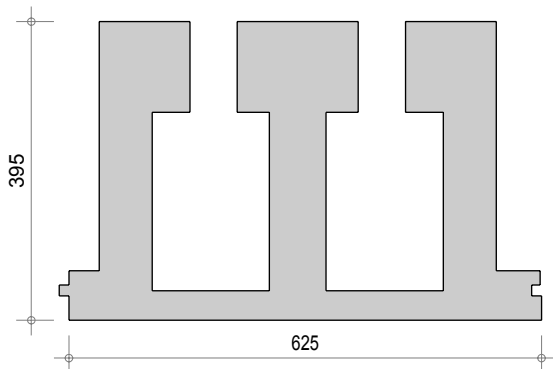

LIGNOTREND Produktions GmbH Landstrasse 25 D-79809 Weilheim-Bannholz Tel : 07755-9200 0 Fax : 07755-9200 55		LIGNO ■ TREND® <small>Ainsi construit notre génération.</small>			
Projet		LIGNOTREND			
Plan-Nr.		Dalle R Q3 BV			
02-02-22		Coupe de principe			
<small>erstellt</small>	<small>Größe</small>	<small>Maßstab</small>	<small>geändert</small>	<small>geändert</small>	<small>geändert</small>
01-01-2008 / AF	A4	1:10			
Dalle R Q3 BV 2008.2d					

Dalle R Q4 Standard

Dalle R Q4 joint creux de 3mm

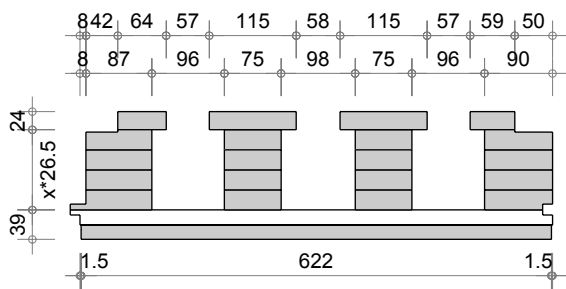

Dalle R Q4 joint V de 7,9mm

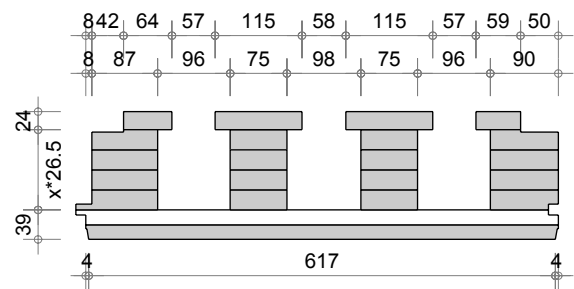

Dalle R Q4 alpha (625-12-4,
Profondeur: 12mm)

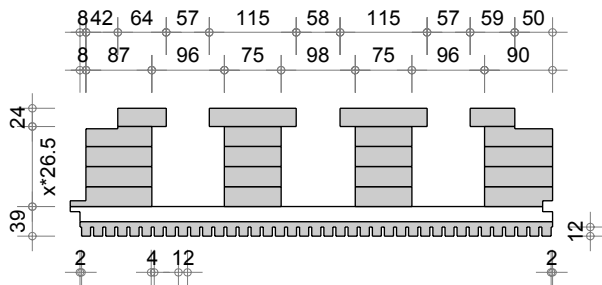

Dalle R Q4 alpha (625-25-8,
Profondeur: 12mm)

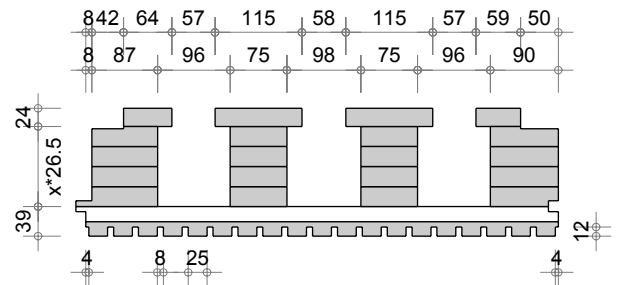

Dalle R Q4 Acoustique alpha (625-12-4)

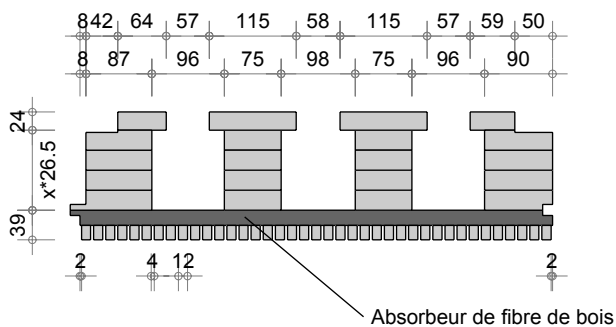

Dalle R Q4 Acoustique alpha (625-25-8)

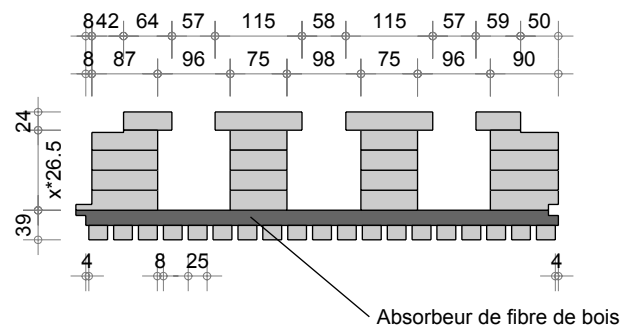

LIGNOTREND Productions GmbH
Landstrasse 25 D-79809 Weilheim-Bannholz
Tel : 07755-9200 0 Fax : 07755-9200 55

LIGNO TREND®
Ainsi construit notre génération.

Projet LIGNOTREND

Plan-Nr. Dalle R Q4
04-03-20 Standard

erstellt	Größe	Maßstab	geändert	geändert	geändert
01-01-2008 / AF	A4	1:10			

Dalle R Q4 2008.2d

Dalle R Q4 Standard

Dalle R Q4 coupe long.



Dalle R Q4 Acoustique coupe long.

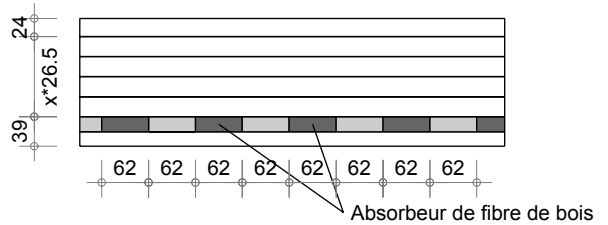

Dalle R Q4 pièce de liaison

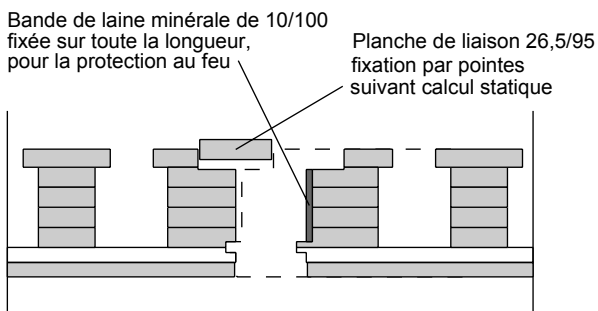

LIGNOTREND Produktions GmbH
Landstrasse 25 D-79809 Weilheim-Bannholz
Tel : 07755-9200 0 Fax : 07755-9200 55

LIGNO TREND®
Ainsi construit notre génération.

Projet LIGNOTREND

Plan-Nr. Dalle R Q4
04-03-21 Standard

erstellt	Größe	Maßstab	geändert	geändert	geändert
01-01-2008 / AF	A4	1:10			

Dalle R Q4 2008.2d

Dalle R Q4 Z1

Dalle R Q4 Z1 joint creux de 3mm

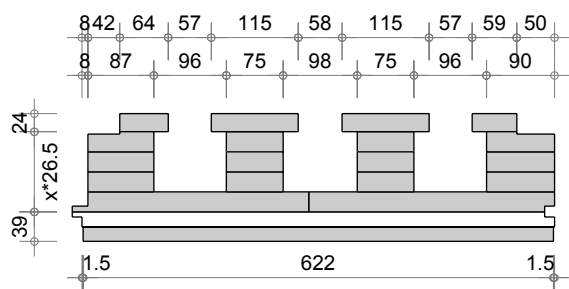

Dalle R Q4 Z1 joint V de 7,9mm

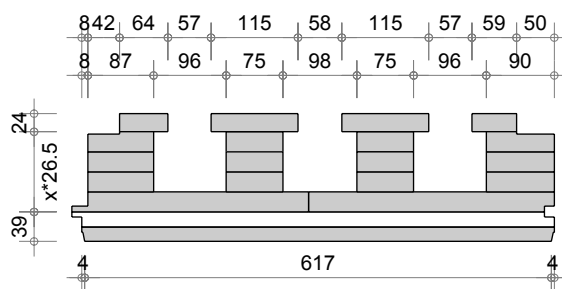

Dalle R Q4 alpha Z1 (625-12-4,
Profondeur: 12mm)

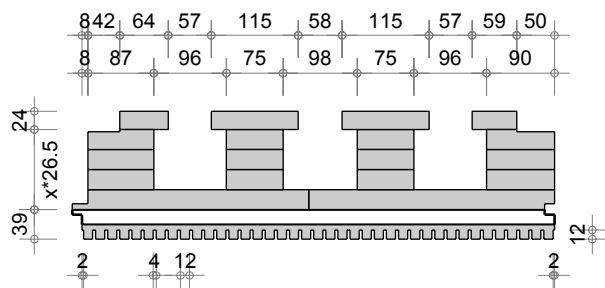

Dalle R Q4 alpha Z1 (625-25-8,
Profondeur: 12mm)

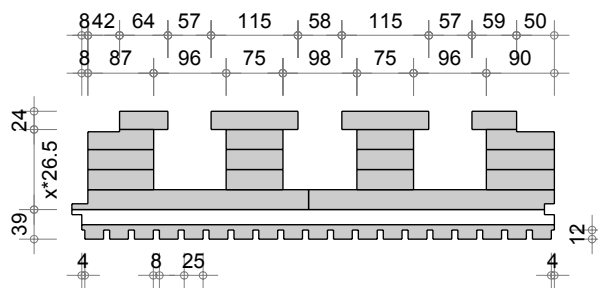

Dalle R Q4 Acoustique alpha Z1 (625-12-4)

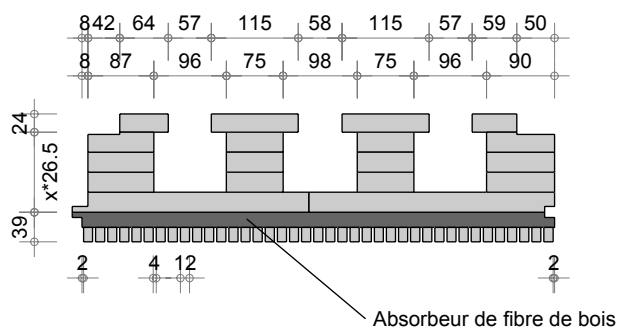

Dalle R Q4 Acoustique alpha Z1 (625-25-8)

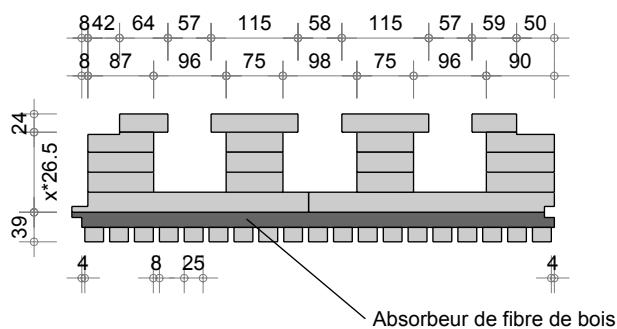

LIGNOTREND Productions GmbH
Landstrasse 25 D-79809 Weilheim-Bannholz
Tel : 07755-9200 0 Fax : 07755-9200 55

LIGNO TREND®
Ainsi construit notre génération.

Projet LIGNOTREND

Plan-Nr. Dalle R Q4
04-03-22 Z1

erstellt	Größe	Maßstab	geändert	geändert	geändert
01-01-2008 / AF	A4	1:10			
Dalle R Q4 2008.2d					

Dalle R Q4 coupe de principe

Dalle R Q4 90

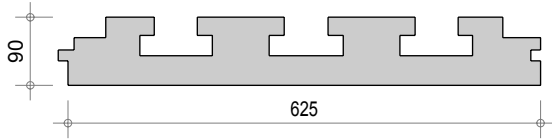

Dalle R Q4 116

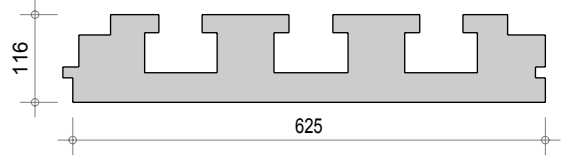

Dalle R Q4 143

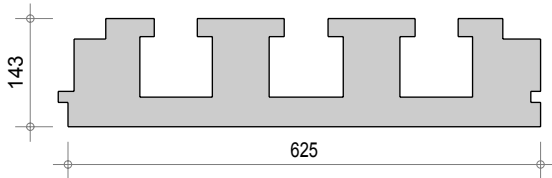

Dalle R Q4 169

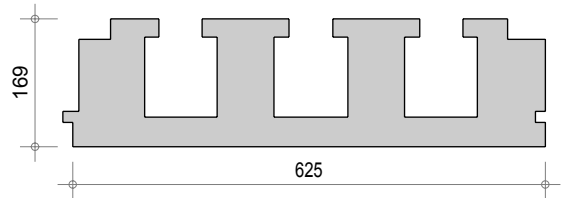

Dalle R Q4 196

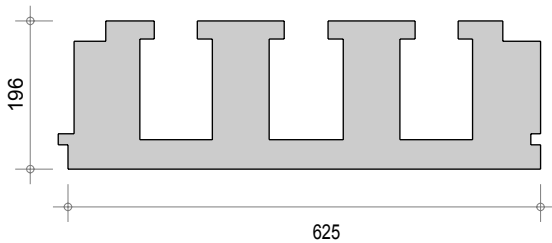

Dalle R Q4 222

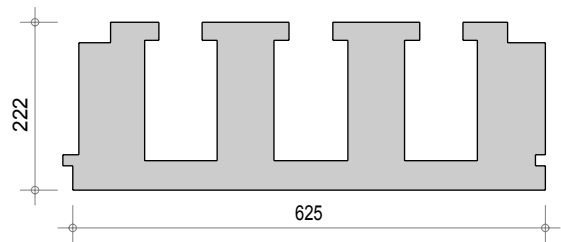

Dalle R Q4 249

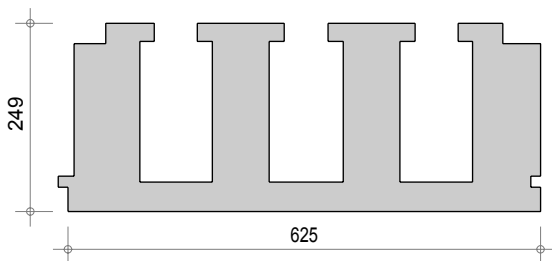

Dalle R Q4 275

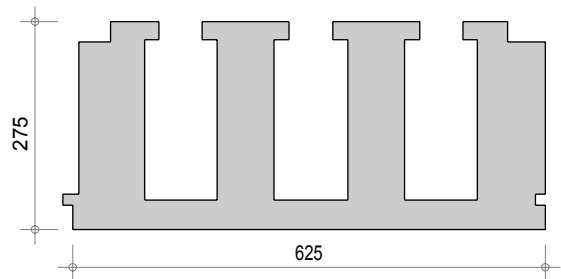

LIGNOTREND Produktions GmbH
Landstrasse 25 D-79809 Weilheim-Bannholz
Tel : 07755-9200 0 Fax : 07755-9200 55

LIGNO TREND®
Ainsi construit notre génération.

Projet LIGNOTREND

Plan-Nr. Dalle R Q4
04-03-23 Coupe de principe

erstellt	Größe	Maßstab	geändert	geändert	geändert
01-01-2008 / AF	A4	1:10			

Dalle R Q4 2008.2d

Bloc Q Standard

Bloc Q Joint creux de 3mm

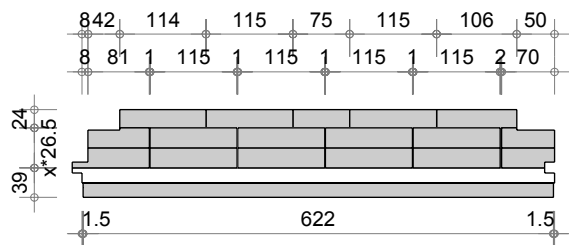

Bloc Q Jonit V de 7,9mm

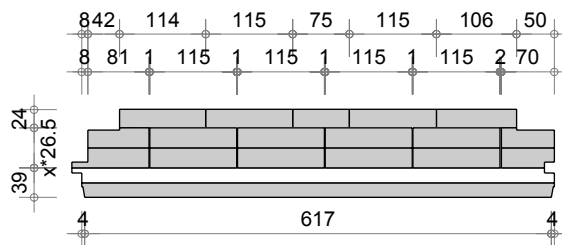

Bloc Q alpha (625-12-4, Profondeur: 12mm)

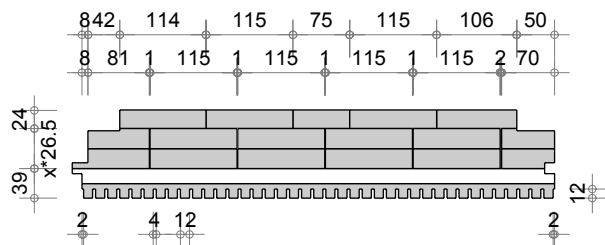

Bloc Q alpha (625-25-8, Profondeur: 12mm)

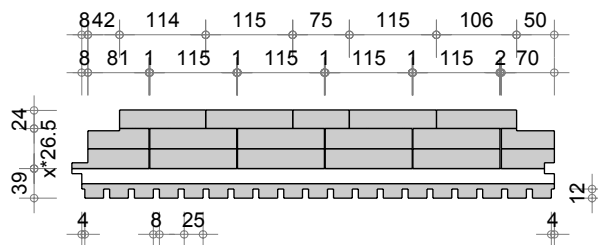

Bloc Q Acoustique alpha (625-12-4)

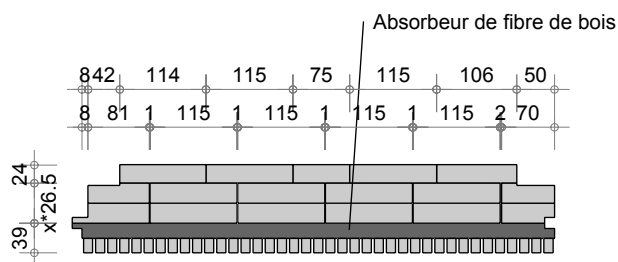

Bloc Q Acoustique alpha (625-25-8)

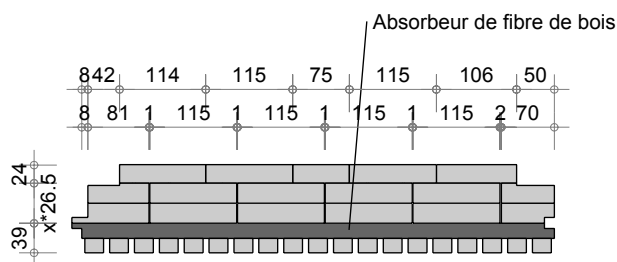

LIGNOTREND Produktions GmbH
Landstrasse 25 D-79809 Weilheim-Bannholz
Tel : 07755-9200 0 Fax : 07755-9200 55

LIGNO TREND®
Ainsi construit notre génération.

Projet LIGNOTREND

Plan-Nr. Bloc Q
03-01-20 Standard

erstellt	Größe	Maßstab	geändert	geändert	geändert
01-01-2008 / AF	A4	1:10			
Bloc Q 2008.2d					

Bloc Q Standard

Bloc Q coupe long.

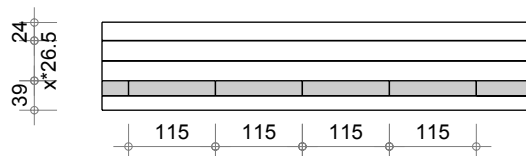

Bloc Q Acoustique coupe long.

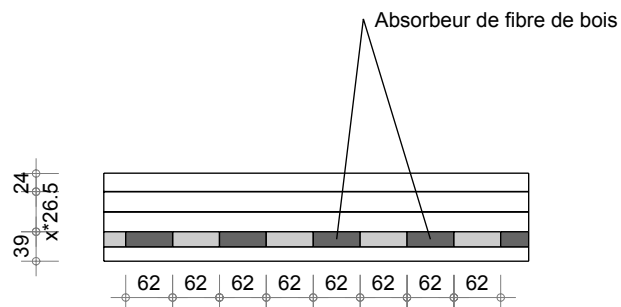

Bloc Q Pièce de liaison

Bande de laine minérale de 10/100 fixée sur toute la longueur, pour la protection au feu

Planche de liaison 26,5/95 fixation par pointes suivant calcul statique

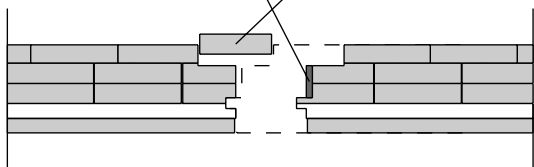

LIGNOTREND Produktions GmbH
Landstrasse 25 D-79809 Weilheim-Bannholz
Tel : 07755-9200 0 Fax : 07755-9200 55

LIGNO TREND®
Ainsi construit notre génération.

Projet LIGNOTREND

Plan-Nr. Bloc Q
03-01-21 Standard

erstellt	Größe	Maßstab	geändert	geändert	geändert
01-01-2008 / AF	A4	1:10			

Bloc Q 2008.2d

Bloc Q Coupe de principe

Bloc Q 90

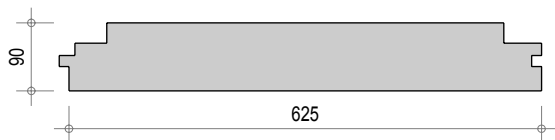

Bloc Q 116

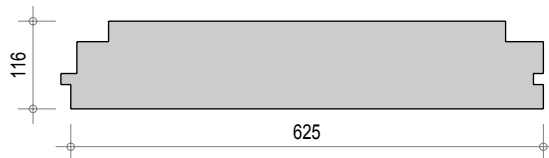

Bloc Q 143



LIGNOTREND Produktions GmbH Landstrasse 25 D-79809 Weilheim-Bannholz Tel : 07755-9200 0 Fax : 07755-9200 55		LIGNO ■ TREND® <small>Ainsi construit notre génération.</small>			
Projet		LIGNOTREND			
Plan-Nr. 03-01-22		Bloc Q Coupe de principe			
erstellt	Größe	Maßstab	geändert	geändert	geändert
01-01-2008 / AF	A4	1:10			
Bloc Q 2008.2d					

Bloc Q3 Standard

Bloc Q3 joint creux de 3mm

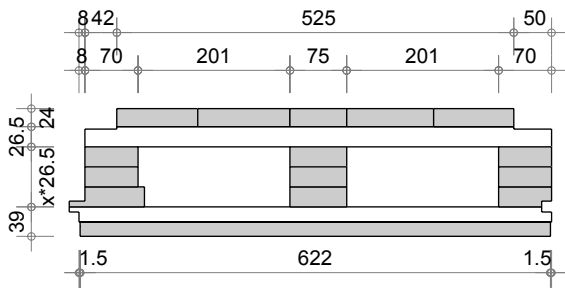

Bloc Q3 joint V de 7,9mm

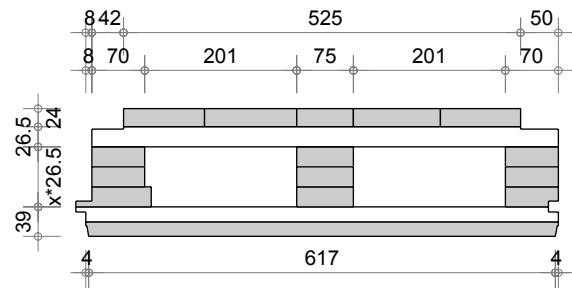

Bloc Q3 alpha (625-12-4,
Profondeur: 12mm)

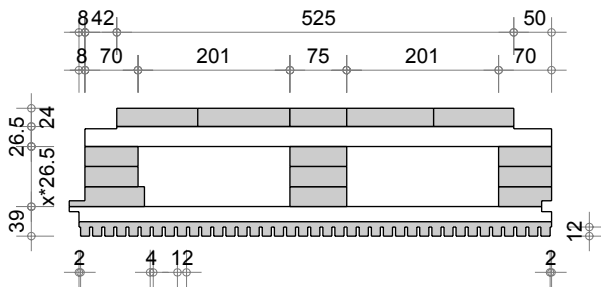

Bloc Q3 alpha (625-25-8,
Profondeur: 12mm)

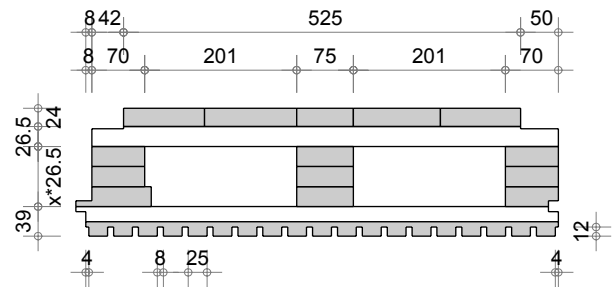

Bloc Q3 Acoustique alpha (625-12-4)

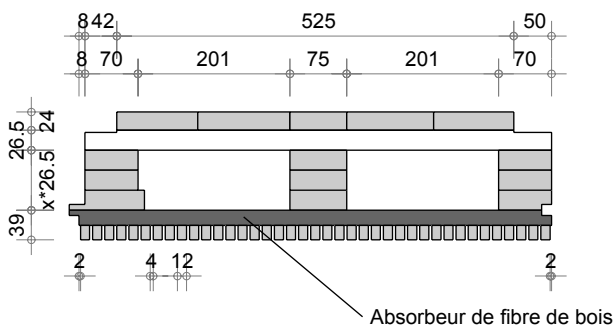

Bloc Q3 Acoustique alpha (625-25-8)

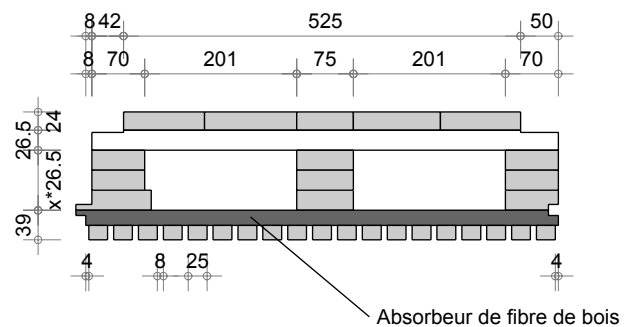

LIGNOTREND Produktions GmbH
Landstrasse 25 D-79809 Weilheim-Bannholz
Tel : 07755-9200 0 Fax : 07755-9200 55

LIGNO TREND®
Ainsi construit notre génération.

Projet LIGNOTREND

Plan-Nr. Bloc Q3
03-02-20 Standard

erstellt	Größe	Maßstab	geändert	geändert	geändert
01-01-2008 / AF	A4	1:10			

Bloc Q3 2008.2d

Bloc Q3 Standard

Bloc Q3 coupe long.

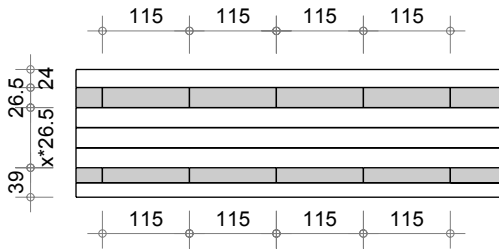

Bloc Q3 Acoustique coupe long.

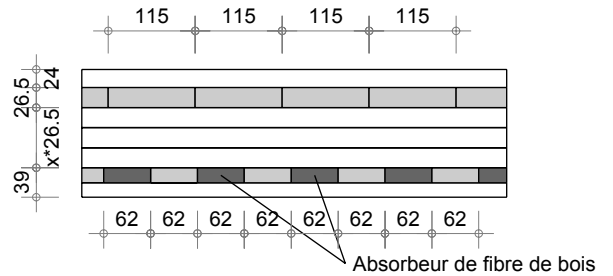

Bloc Q3 pièce de liaison

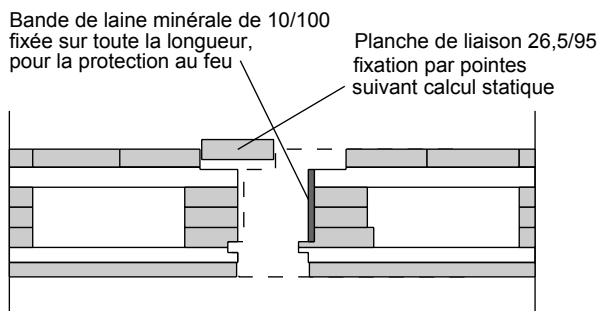

LIGNOTREND Produktions GmbH
Landstrasse 25 D-79809 Weilheim-Bannholz
Tel : 07755-9200 0 Fax : 07755-9200 55

LIGNO TREND®
Ainsi construit notre génération.

Projet LIGNOTREND

Plan-Nr. Bloc Q3
03-02-21 Standard

erstellt	Größe	Maßstab	geändert	geändert	geändert
01-01-2008 / AF	A4	1:10			

Bloc Q3 2008.2d

Bloc Q3 Z1

Bloc Q3 Z1 joint creux de 3mm

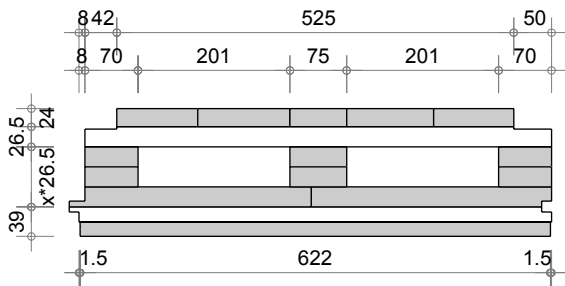

Bloc Q3 Z1 joint V de 7,9mm

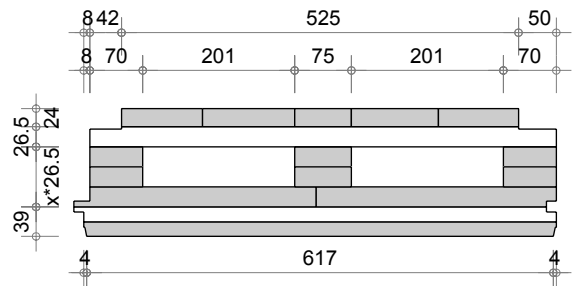

Bloc Q3 alpha Z1 (625-12-4,
Profondeur: 12mm)

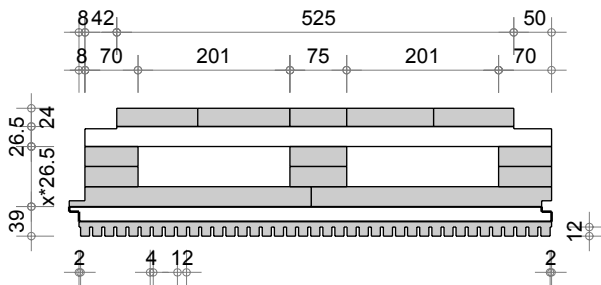

Bloc Q3 alpha Z1 (625-25-8,
Profondeur: 12mm)

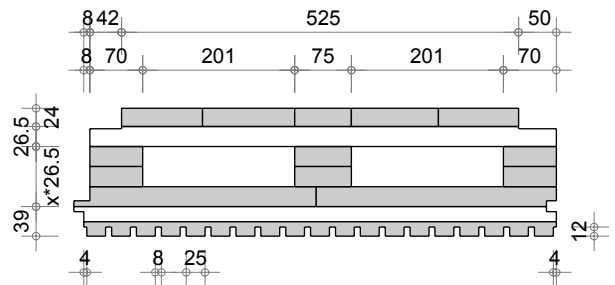

Bloc Q3 Acoustique alpha Z1 (625-12-4)

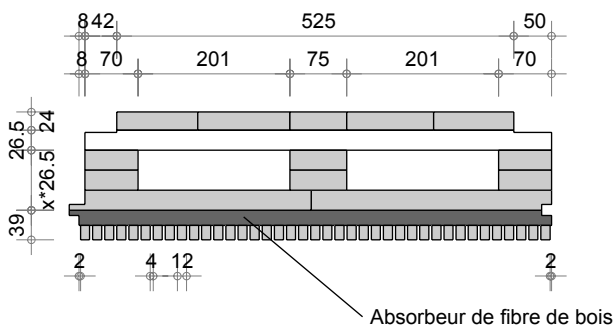

Bloc Q3 Acoustique alpha Z1 (625-25-8)

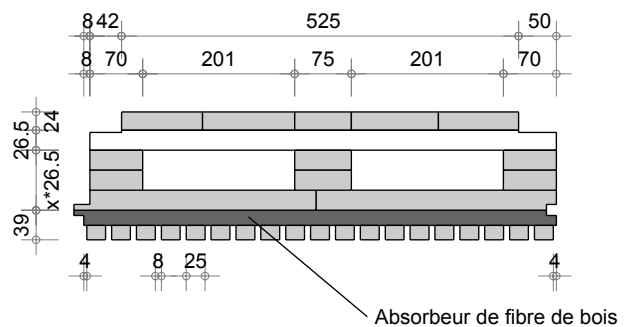

LIGNOTREND Produktions GmbH
Landstrasse 25 D-79809 Weilheim-Bannholz
Tel : 07755-9200 0 Fax : 07755-9200 55

LIGNO TREND®
Ainsi construit notre génération.

Projet LIGNOTREND

Plan-Nr. Bloc Q3
03-02-22 Z1

erstellt	Größe	Maßstab	geändert	geändert	geändert
01-01-2008 / AF	A4	1:10			

Bloc Q3 2008.2d

Bloc Q3 coupe de principe

Bloc Q3 143

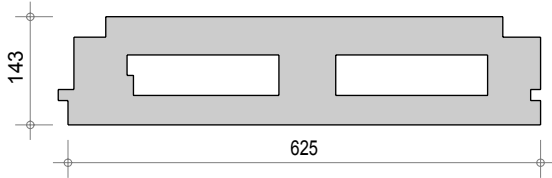

Bloc Q3 169

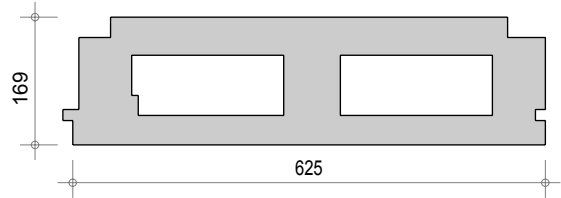

Bloc Q3 196

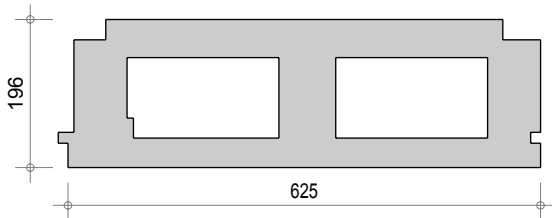

Bloc Q3 222

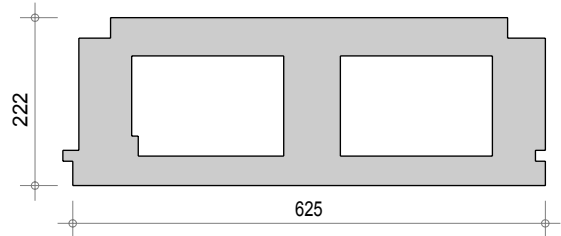

Bloc Q3 249

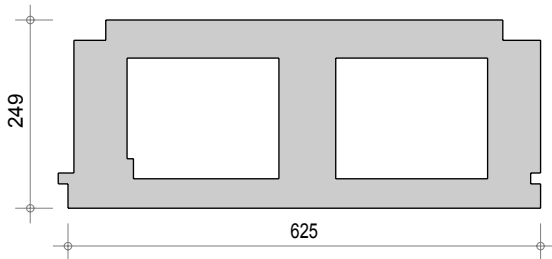

Bloc Q3 275

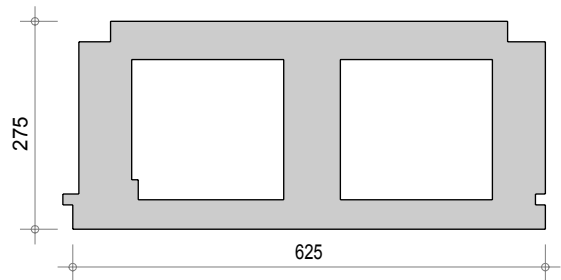

LIGNOTREND Produktions GmbH
Landstrasse 25 D-79809 Weilheim-Bannholz
Tel : 07755-9200 0 Fax : 07755-9200 55

LIGNO ■ TREND®
Ainsi construit notre génération.

Projet LIGNOTREND

Plan-Nr. Bloc Q3
03-02-23 Coupe de principe

erstellt	Größe	Maßstab	geändert	geändert	geändert
01-01-2008 / AF	A4	1:10			

Bloc Q3 2008.2d

Bloc Q3 BV Standard

Bloc Q3 BV Joint creux de 3mm

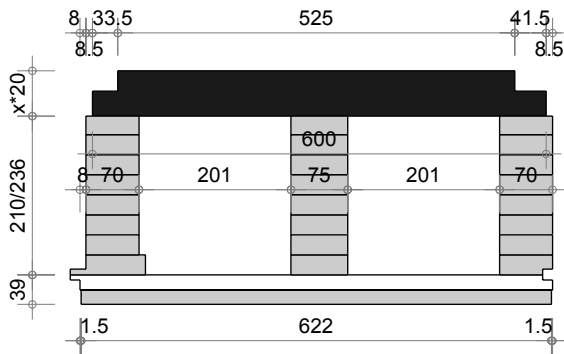

Bloc Q3 BV Joint V de 7,9mm

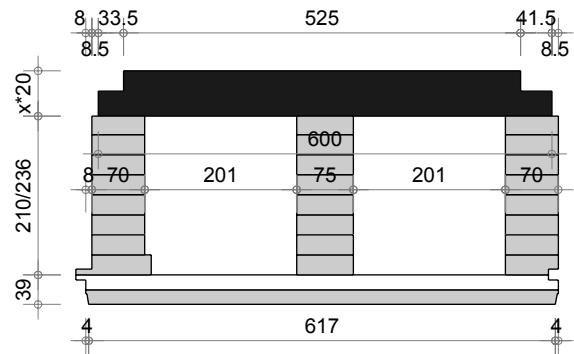

Bloc Q3 alpha BV (625-12-4, P.: 12mm)

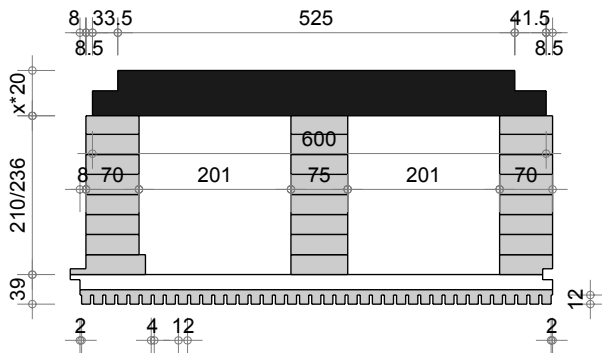

Bloc Q3 alpha BV (625-25-8, P.: 12mm)

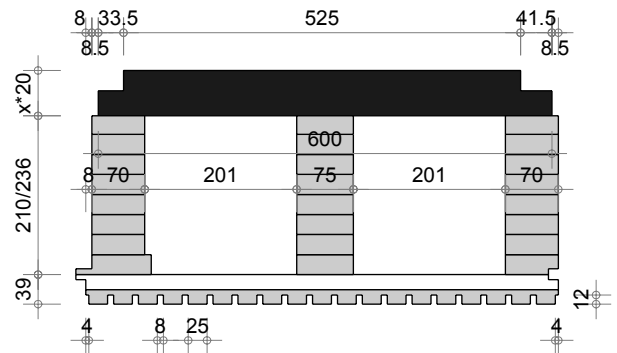

Bloc Q3 Acoustique alpha BV (625-12-4)

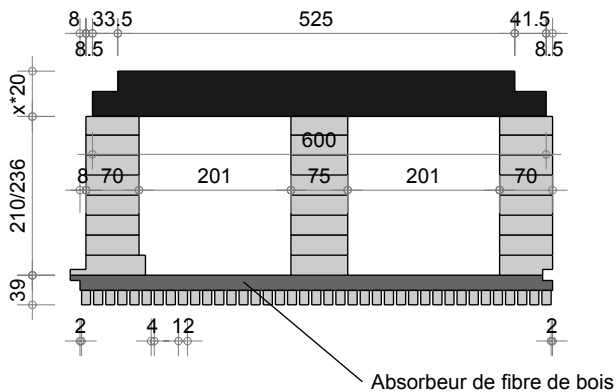

Bloc Q3 Acoustique alpha BV (625-25-8)

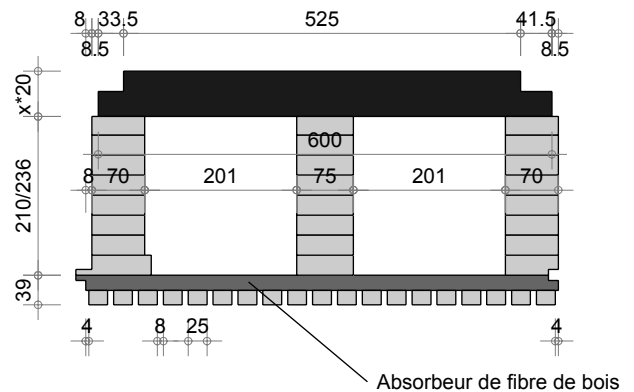

LIGNOTREND Produktions GmbH
Landstrasse 25 D-79809 Weilheim-Bannholz
Tel : 07755-9200 0 Fax : 07755-9200 55

LIGNO TREND®
Ainsi construit notre génération.

Projet LIGNOTREND

Plan-Nr. Bloc Q3 BV
03-03-20 Standard

erstellt	Größe	Maßstab	geändert	geändert	geändert
01-01-2008 / AF	A4	1:10			

Bloc Q3 BV 2008.2d

Bloc Q3 BV Standard

Bloc Q3 BV coupe long.

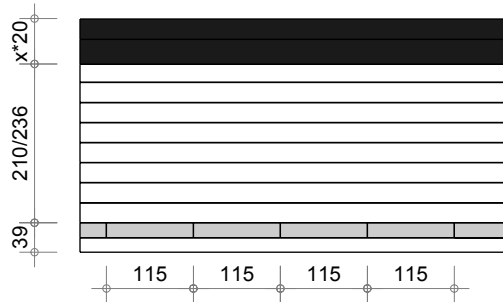

Bloc Q3 Acoustique BV coupe long.

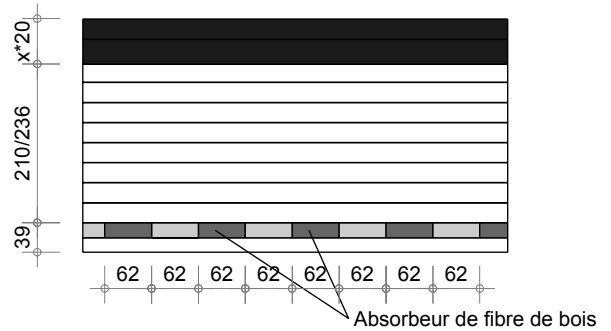

Bloc Q3 BV Pièce de liaison

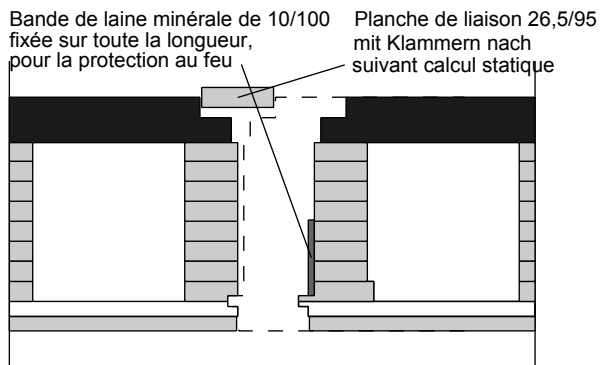

LIGNOTREND Produktions GmbH Landstrasse 25 D-79809 Weilheim-Bannholz Tel : 07755-9200 0 Fax : 07755-9200 55		LIGNO TREND® <small>Ainsi construit notre génération.</small>			
Projet		LIGNOTREND			
Plan-Nr. 03-03-21		Bloc Q3 BV Standard			
erstellt	Größe	Maßstab	geändert	geändert	geändert
01-01-2008 / AF	A4	1:10			
Bloc Q3 BV 2008.2d					

Bloc Q3 Z1 BV

Bloc Q3 Z1 BV Joint creux de 3mm

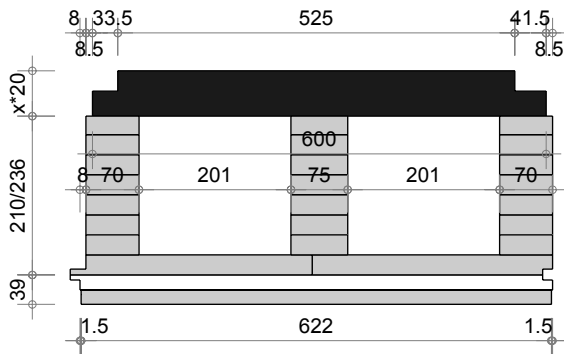

Bloc Q3 Z1 BV Joint V de 7,9mm

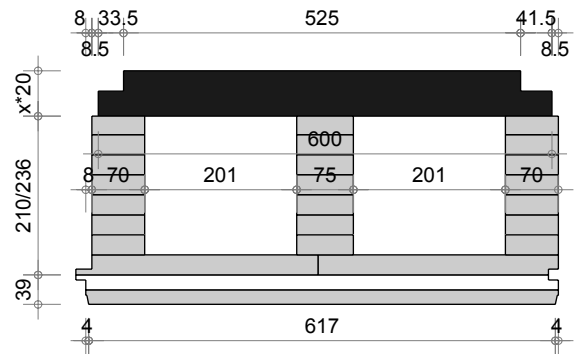

Bloc Q3 alpha Z1 BV (625-12-4, P.: 12mm)

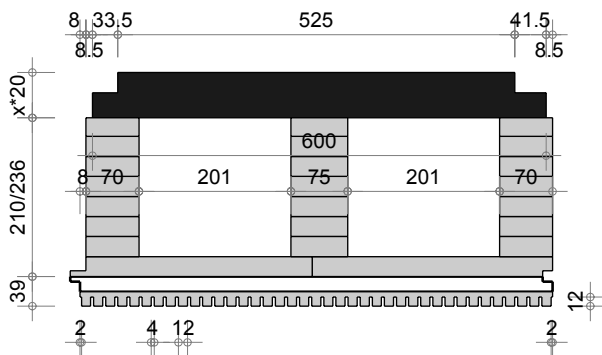

Bloc Q3 alpha Z1 BV (625-25-8, P.: 12mm)

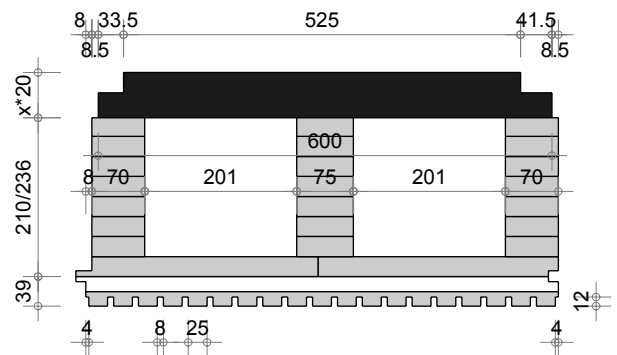

Bloc Q3 Acoustique alpha Z1 BV (625-12-4)

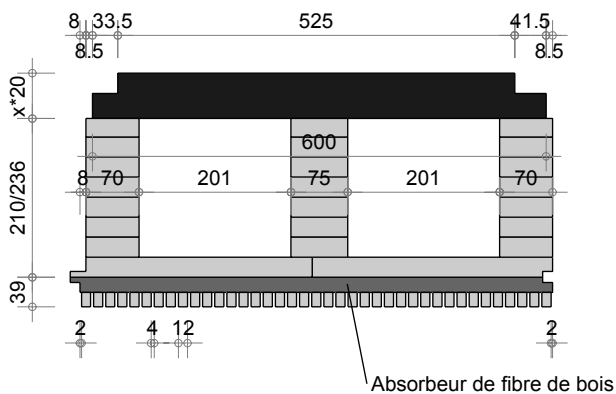

Bloc Q3 Acoustique alpha Z1 BV (625-25-8)

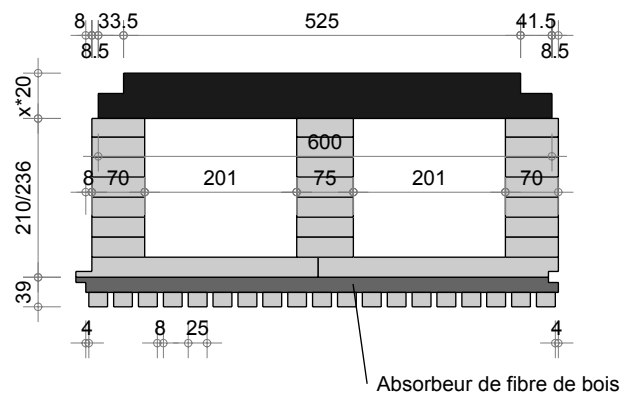

LIGNOTREND Produktions GmbH
Landstrasse 25 D-79809 Weilheim-Bannholz
Tel : 07755-9200 0 Fax : 07755-9200 55

LIGNO TREND®
Ainsi construit notre génération.

Projet LIGNOTREND

Plan-Nr. Bloc Q3 BV
03-03-22 Z1

erstellt	Größe	Maßstab	geändert	geändert	geändert
01-01-2008 / AF	A4	1:10			

Bloc Q3 BV 2008.2d

Bloc Q3 BV Coupe de principe

Bloc Q3 BV 309

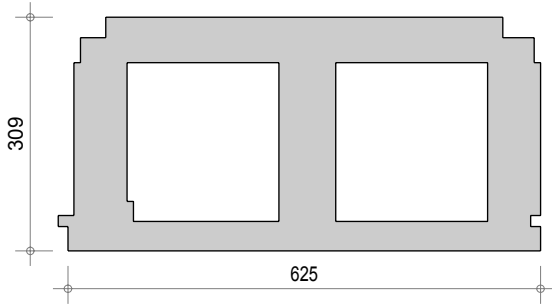

Bloc QV BV 335

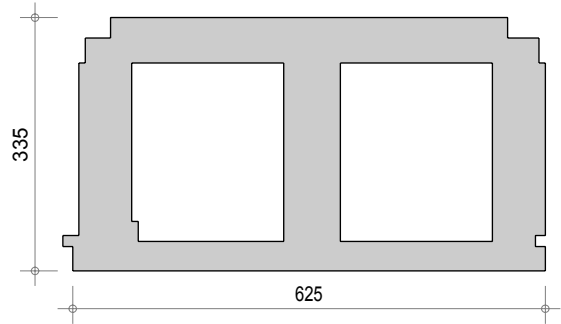

Bloc Q3 BV 355

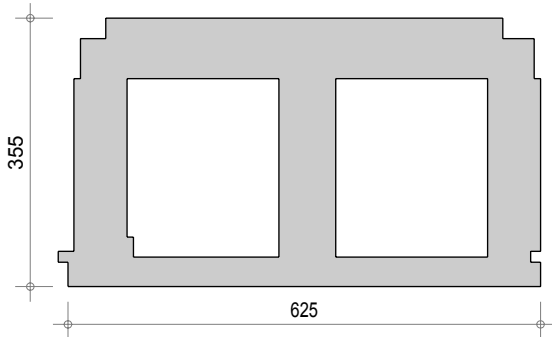

Bloc Q3 BV 375

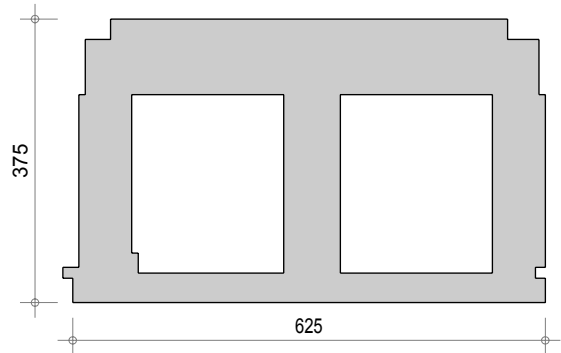

Bloc Q3 BV 395

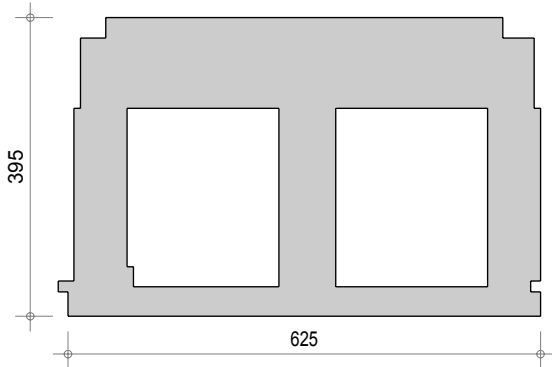

Bloc Q3 BV 415

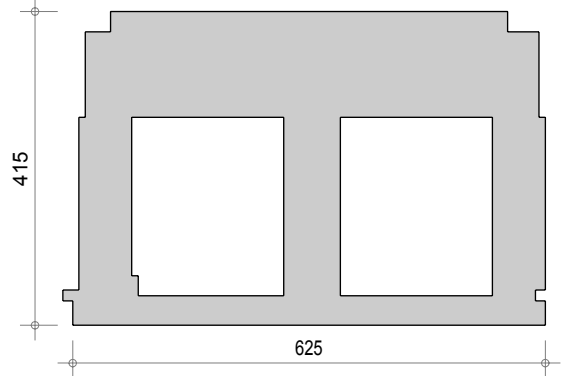

Bloc Q3 BV 435

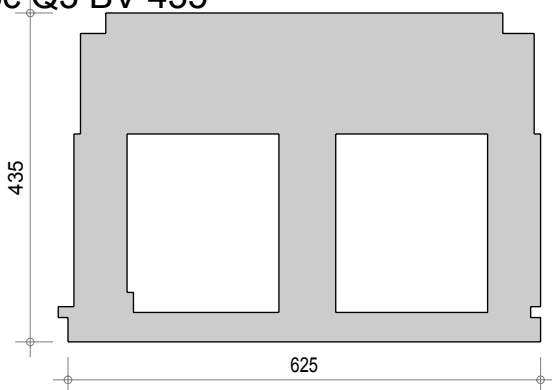

LIGNOTREND Produktions GmbH
Landstrasse 25 D-79809 Weilheim-Bannholz
Tel : 07755-9200 0 Fax : 07755-9200 55

LIGNO TREND®
Ainsi construit notre génération.

Projet LIGNOTREND

Plan-Nr. Bloc Q3 BV
03-03-23 Coupe de principe

erstellt	Größe	Maßstab	geändert	geändert	geändert
01-01-2008 / AF	A4	1:10			

Bloc Q3 BV 2008.2d

Acoustique classique standard

Acoustique Q classique

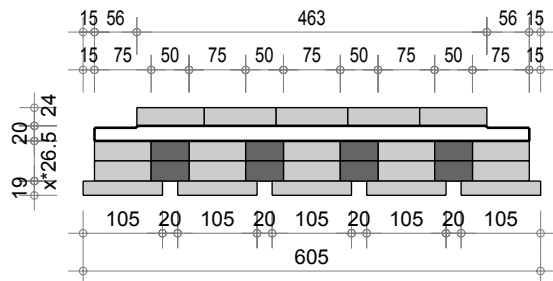

Acoustique Q3 classique

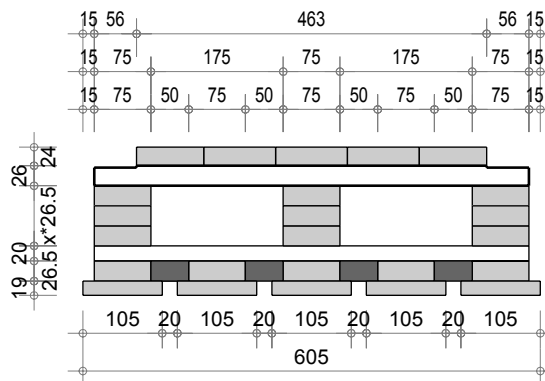

Acoustique Q3 classique BV

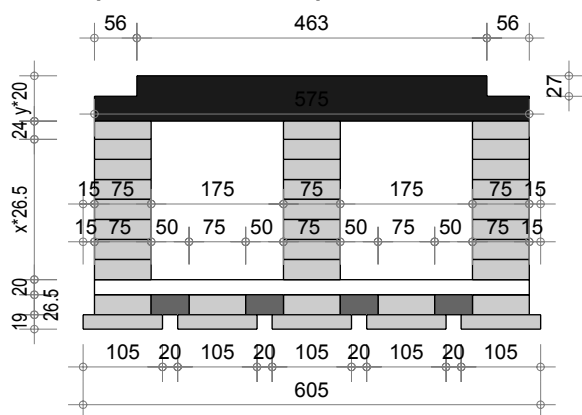

Acoustique Q/Q3 classique pièce de liaison

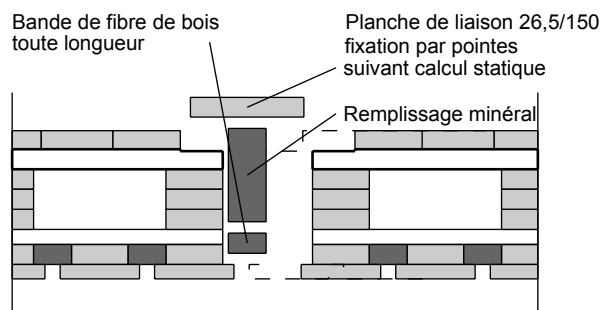

Acoustique Q classique coupe long.

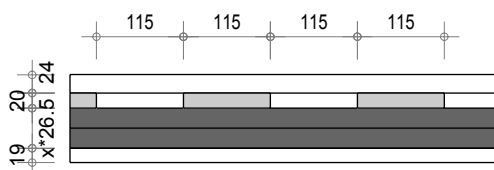

Acoustique Q3 classique coupe long.

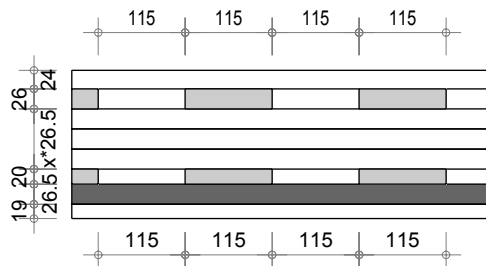

Acoustique Q3 classique BV coupe long.

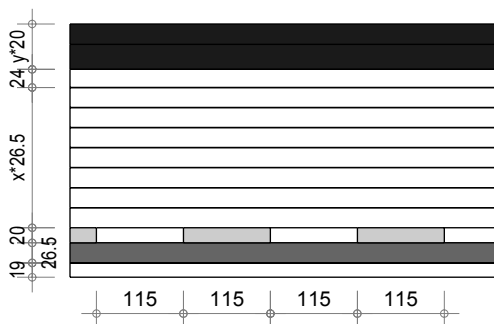

LIGNOTREND Produktions GmbH Landstrasse 25 D-79809 Weilheim-Bannholz Tel : 07755-9200 0 Fax : 07755-9200 55		LIGNO TREND® <small>Ainsi construit notre génération.</small>			
Projet	LIGNOTREND				
Plan-Nr. 05-01-20	Acoustique classique Standard				
erstellt	Größe	Maßstab	geändert	geändert	geändert
01-01-2008 / AF	A4	1:10			
Acoustique classique 2008.2d					

Acoustique classique coupe de principe

Acoustique Q classique 90

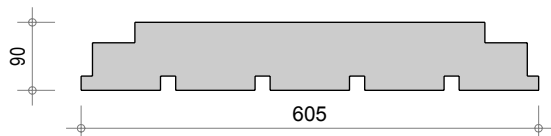

Acoustique Q classique 116

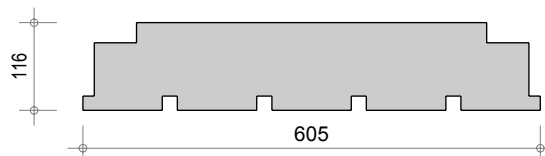

Acoustique Q classique 143

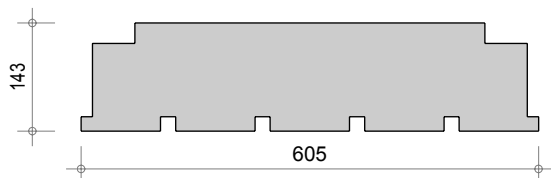

Acoustique Q3 classique 143

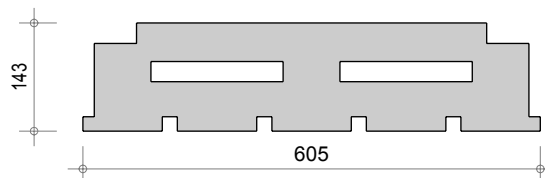

Acoustique Q3 classique 169

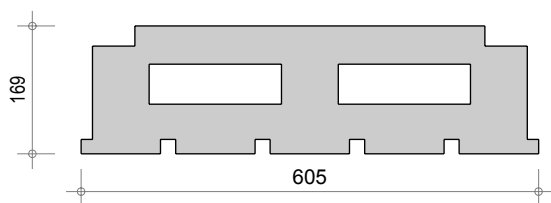

Acoustique Q3 classique 196

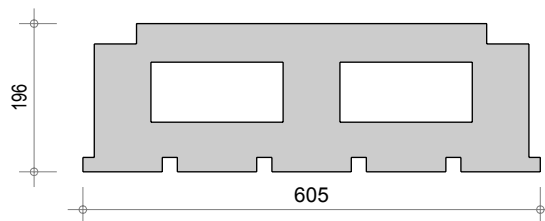

Acoustique Q3 classique 222

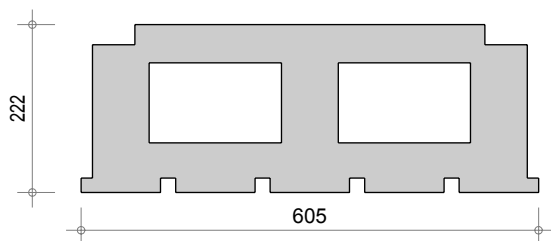

LIGNOTREND Produktions GmbH Landstrasse 25 D-79809 Weilheim-Bannholz Tel : 07755-9200 0 Fax : 07755-9200 55		LIGNO ■ TREND® <small>Ainsi construit notre génération.</small>			
Projet		LIGNOTREND			
Plan-Nr.		Acoustique classique			
05-01-21		Coupe de principe			
<small>erstellt</small>	<small>Größe</small>	<small>Maßstab</small>	<small>geändert</small>	<small>geändert</small>	<small>geändert</small>
01-01-2008 / AF	A4	1:10			
<small>Acoustique classique 2008.2d</small>					

Acoustique classique coupe de principe

Acoustique Q3 classique 249

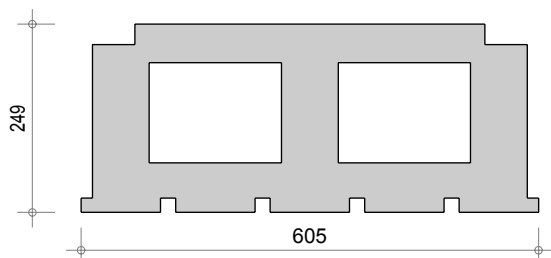

Acoustique Q3 classique 275

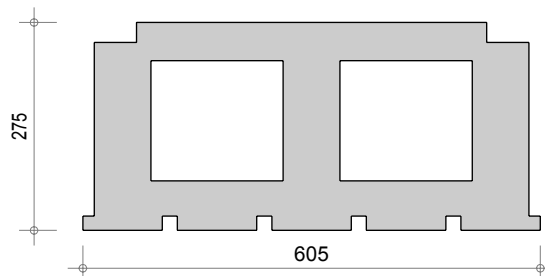

Acoustique Q3 classique 309 BV

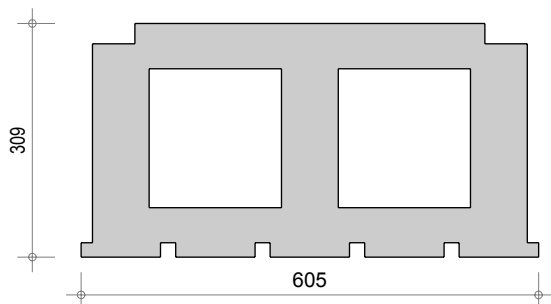

Acoustique Q3 classique 335 BV

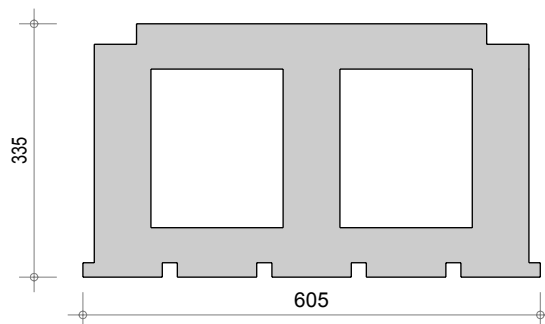

Acoustique Q3 classique 355 BV

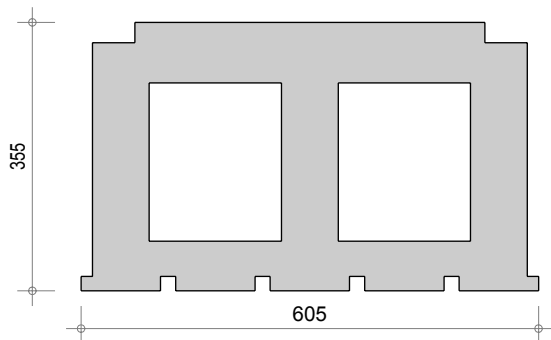

Acoustique Q3 classique 375 BV

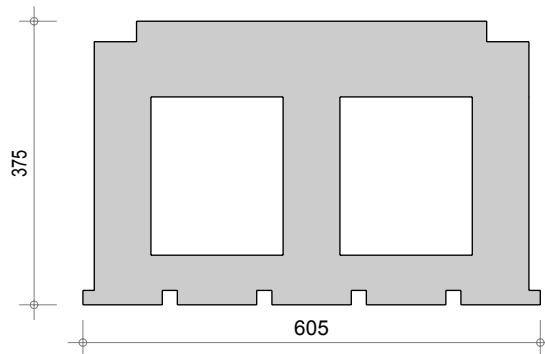

Acoustique Q3 classique 395 BV

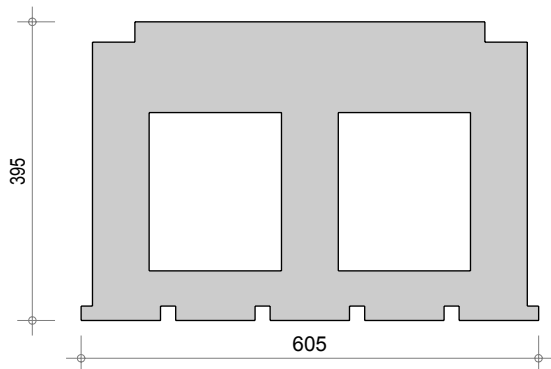

LIGNOTREND Produktions GmbH Landstrasse 25 D-79809 Weilheim-Bannholz Tel : 07755-9200 0 Fax : 07755-9200 55		LIGNO ■ TREND® <small>Ainsi construit notre génération.</small>			
Projet		LIGNOTREND			
Plan-Nr. 05-01-22		Acoustique classique Coupe de principe			
erstellt	Größe	Maßstab	geändert	geändert	geändert
01-01-2008 / AF	A4	1:10			
Acoustique classique 2008.2d					

HBV Q2 Standard

HBV Q2 Joint creux de 3mm

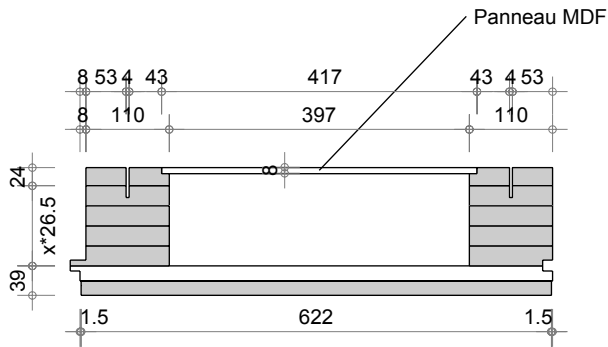

HBV Q2 Joint V de 7,9mm

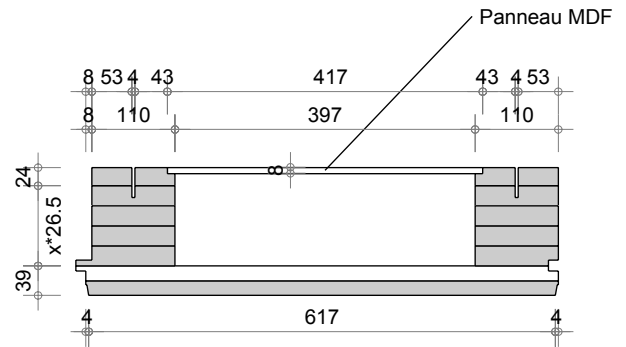

HBV Q2 alpha (625-12-4,
Profondeur: 12mm)

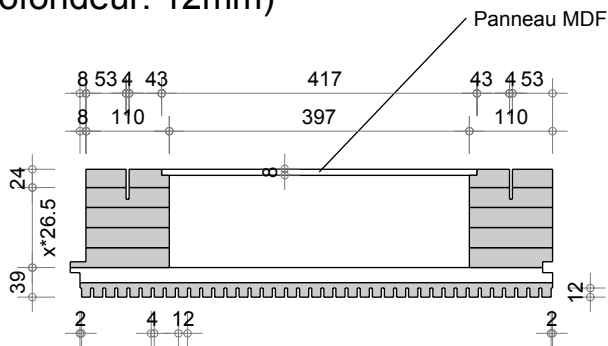

HBV Q2 alpha (625-25-8,
Profondeur: 12mm)

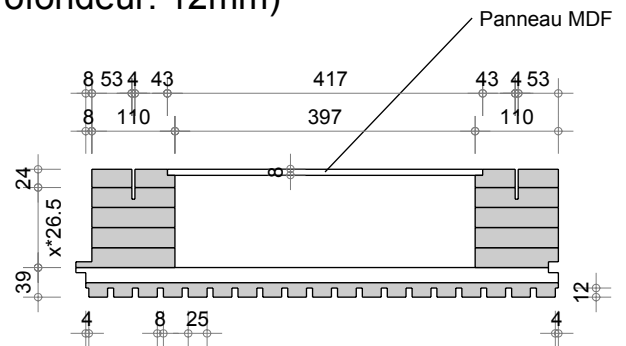

HBV Q2 Acoustique alpha (625-12-4)

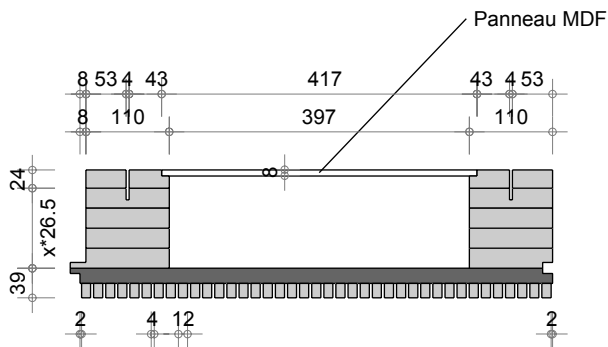

HBV Q2 Acoustique alpha (625-25-8)

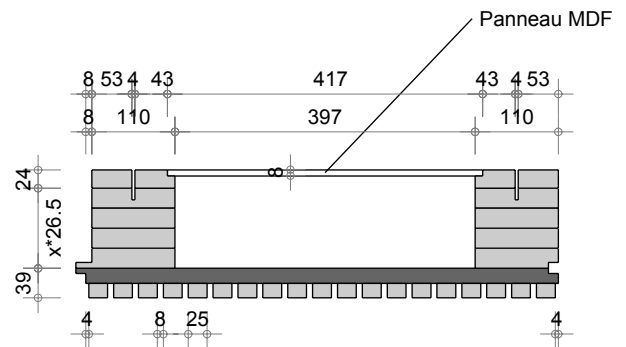

LIGNOTREND Produktions GmbH
Landstrasse 25 D-79809 Weilheim-Bannholz
Tel : 07755-9200 0 Fax : 07755-9200 55

LIGNO TREND®
Ainsi construit notre génération.

Projet LIGNOTREND

Plan-Nr. Dalle Bois-Béton
08-01-20 Standard

erstellt	Größe	Maßstab	geändert	geändert	geändert
01-01-2008 / AF	A4	1:10			

HBV Q2 2008.2d

HBV Q2 Standard

HBV Q2 coupe long.

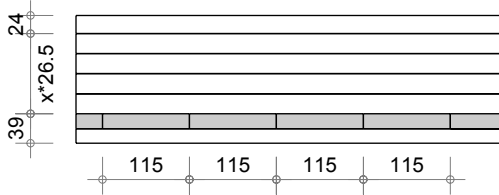

HBV Q2 Acoustique long.

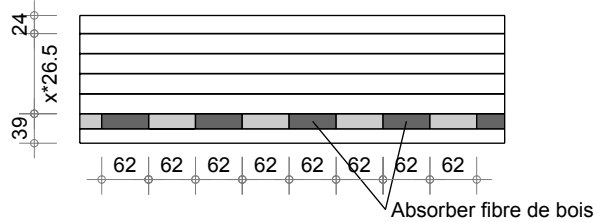

LIGNOTREND Produktions GmbH
Landstrasse 25 D-79809 Weilheim-Bannholz
Tel : 07755-9200 0 Fax : 07755-9200 55

LIGNO TREND®
Ainsi construit notre génération.

Projet LIGNOTREND

Plan-Nr. Dalle Bois-Béton
08-01-21 Standard

erstellt	Größe	Maßstab	geändert	geändert	geändert
01-01-2008 / AF	A4	1:10			

HBV Q2 2008.2d

HBV Q2 Z1

HBV Q2 Z1 Joint creux de 3mm

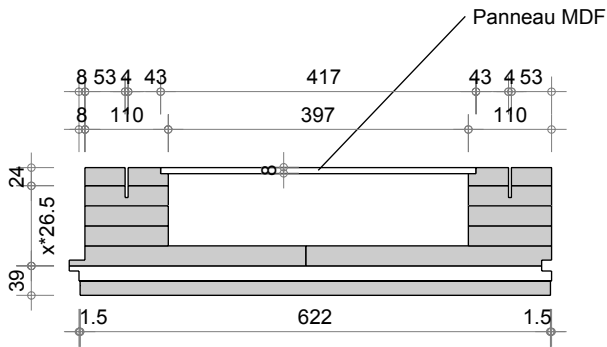

HBV Q2 Z1 Joint V de 7,9mm

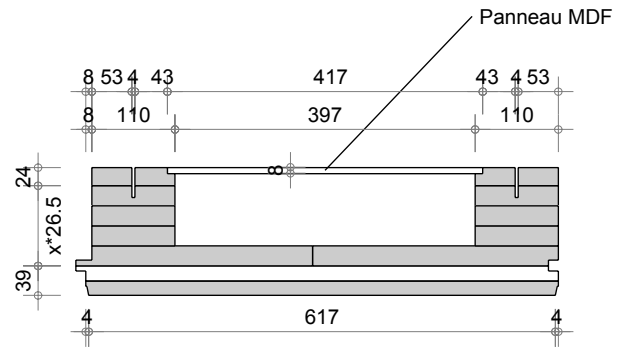

HBV Q2 alpha Z1 (625-12-4,
Profondeur: 12mm)

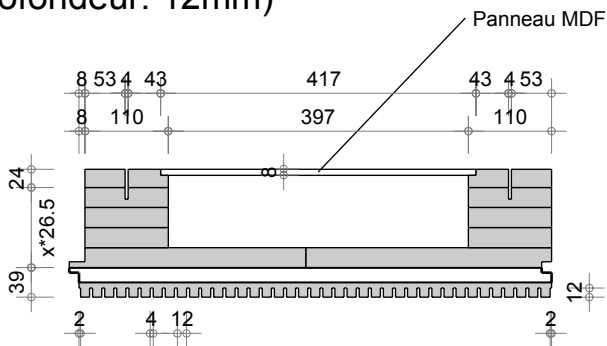

HBV Q2 alpha Z1 (625-25-8,
Profondeur: 12mm)

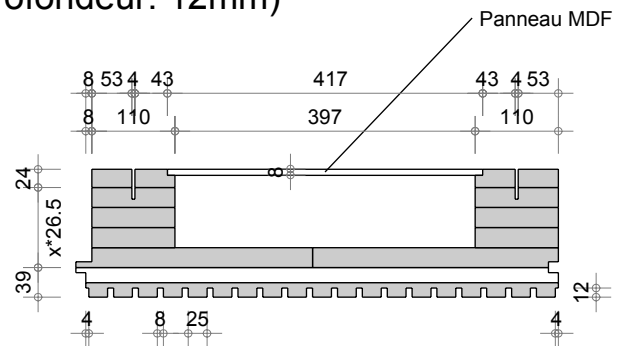

HBV Q2 Acoustique alpha Z1 (625-12-4)

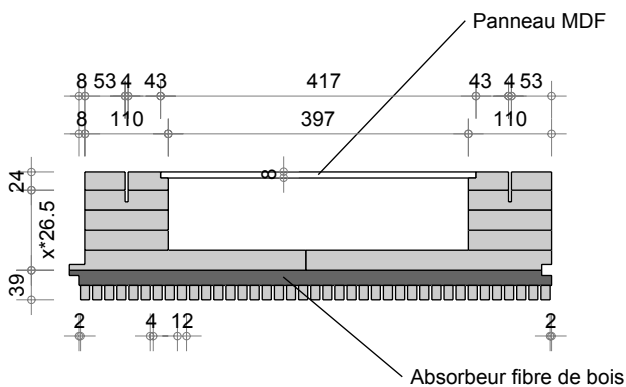

HBV Q2 Acoustique alpha Z1 (625-25-8)

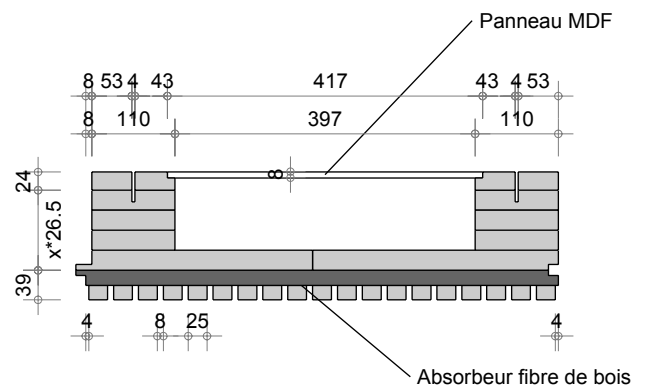

LIGNOTREND Produktions GmbH
Landstrasse 25 D-79809 Weilheim-Bannholz
Tel : 07755-9200 0 Fax : 07755-9200 55

LIGNO TREND®
Ainsi construit notre génération.

Projet LIGNOTREND

Plan-Nr. Dalle Bois-Béton
08-01-22 Z1

erstellt	Größe	Maßstab	geändert	geändert	geändert
01-01-2008 / AF	A4	1:10			

HBV Q2 2008.2d

HBV Q2 Coupe de principe

HBV Q2 143

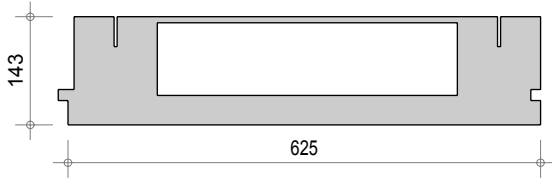

HBV Q2 169

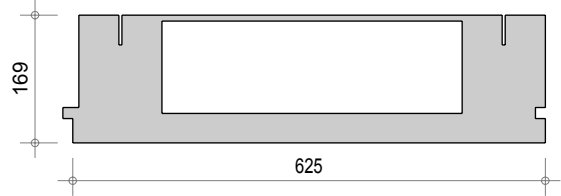

HBV Q2 196

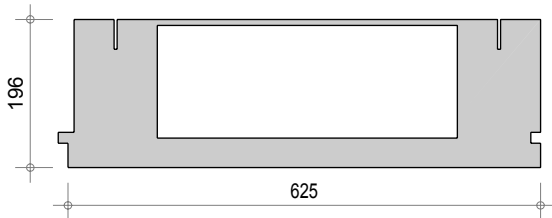

HBV Q2 222

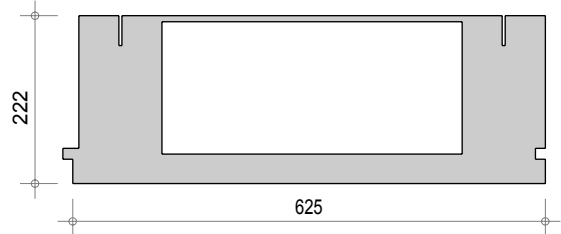

HBV Q2 249

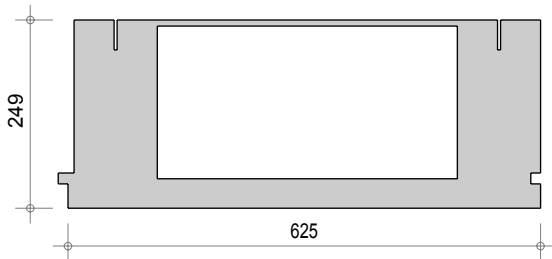

HBV Q2 275

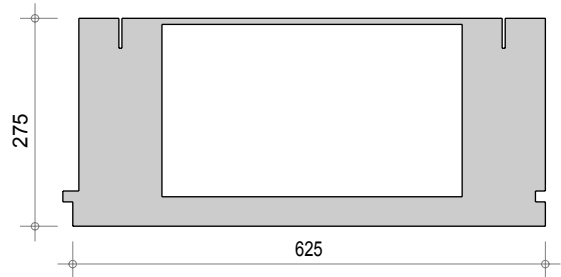

LIGNOTREND Produktions GmbH
Landstrasse 25 D-79809 Weilheim-Bannholz
Tel : 07755-9200 0 Fax : 07755-9200 55

LIGNO ■ TREND®
Ainsi construit notre génération.

Projet LIGNOTREND

Plan-Nr. 08-01-23
Dalle Bois-Béton
Coupe de principe

erstellt	Größe	Maßstab	geändert	geändert	geändert
01-01-2008 / AF	A4	1:10			

HBV Q2 2008.2d

Entretoise U*psi - Type F 120

Type 2940-120 / 59 / 30

Coupe A-A

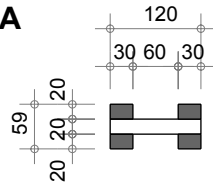

Coupe B-B

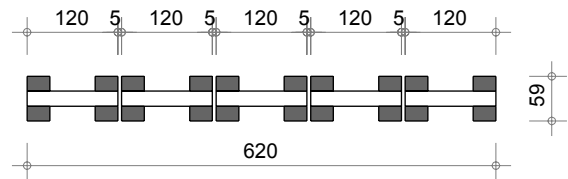
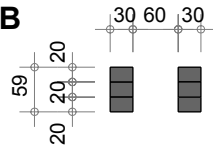

Coupe longitudinale

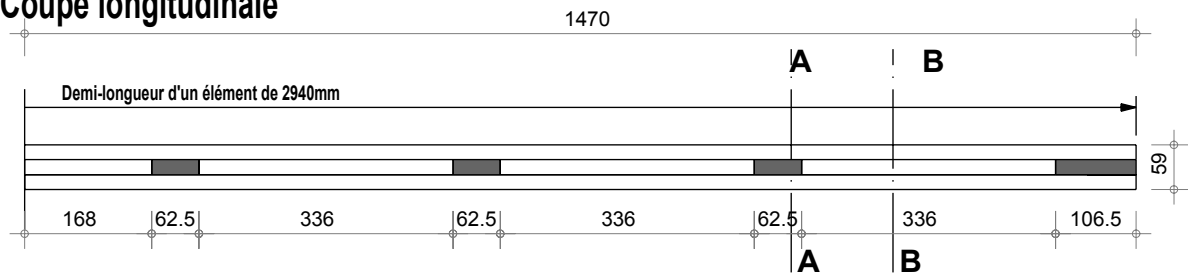

LIGNOTREND Produktions GmbH
Landstrasse 25 D-79809 Weilheim-Bannholz
Tel : 07755-9200 0 Fax : 07755-9200 55

LIGNO ■ TREND®
Ainsi construit notre génération.

Projet LIGNOTREND U*psi

Plan-Nr. LIGNO U*psi Type F 120
U F - 02 Coupe de principe

erstellt	Größe	Maßstab	geändert	geändert	geändert
17-10-2007 / AF	A4	1:10			

Upsi et Sesi.2d

Entretoise U*psi - Type F 200 / F 300

Type 2940-200 / 59 / 40

Coupe A-A

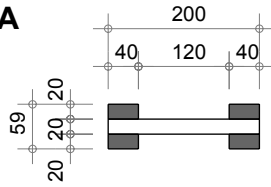

Coupe B-B

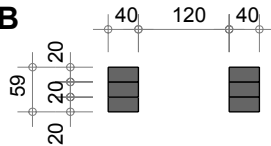

Type 2940-300 / 59 / 40

Coupe A-A

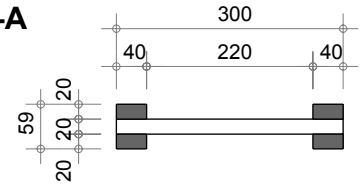

Coupe B-B

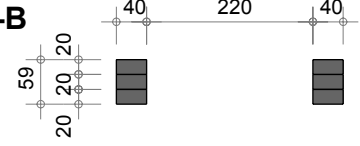

Coupe longitudinale

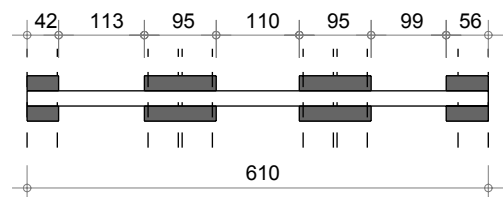
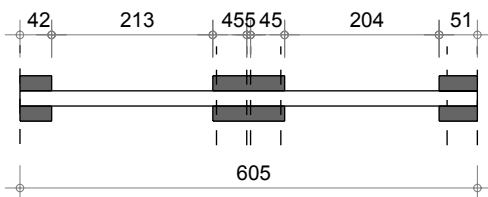
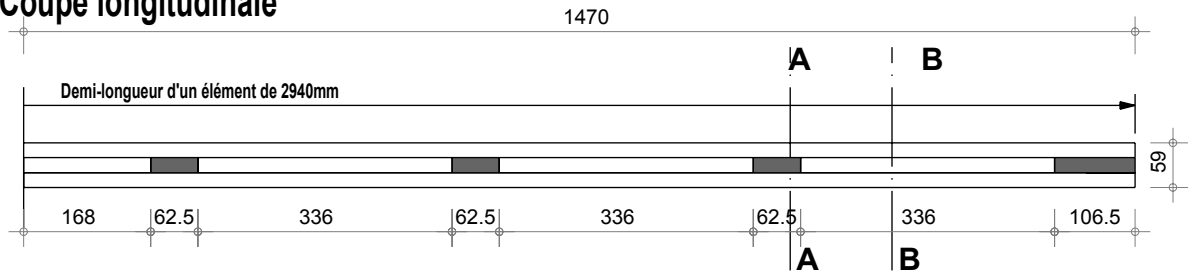

LIGNOTREND Produktions GmbH
Landstrasse 25 D-79809 Weilheim-Bannholz
Tel : 07755-9200 0 Fax : 07755-9200 55

LIGNO TREND®
Ainsi construit notre génération.

Projet

LIGNOTREND U*psi

Plan-Nr.
U F - 04

LIGNO U*psi Type F 200 / F 300
Coupe de principe

erstellt	Größe	Maßstab	geändert	geändert	geändert
17-10-2007 / AF	A4	1:10			

Upsi et Sesi.2d

Entretoise U*psi - Type F 240 / F 360

Type 2940-240 / 59 / 40

Coupe A-A

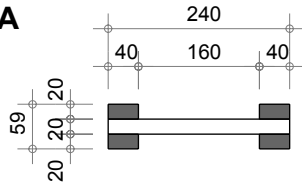

Coupe B-B

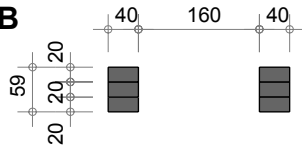

Type 2940-360 / 59 / 40

Coupe A-A

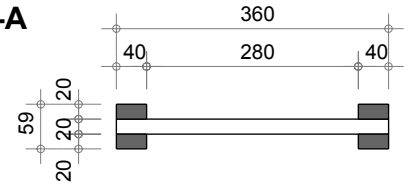

Coupe B-B



Coupe longitudinale

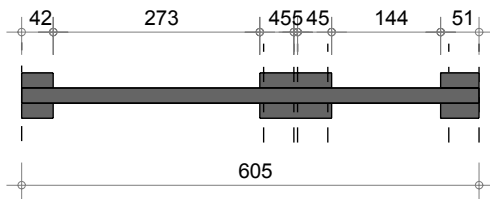
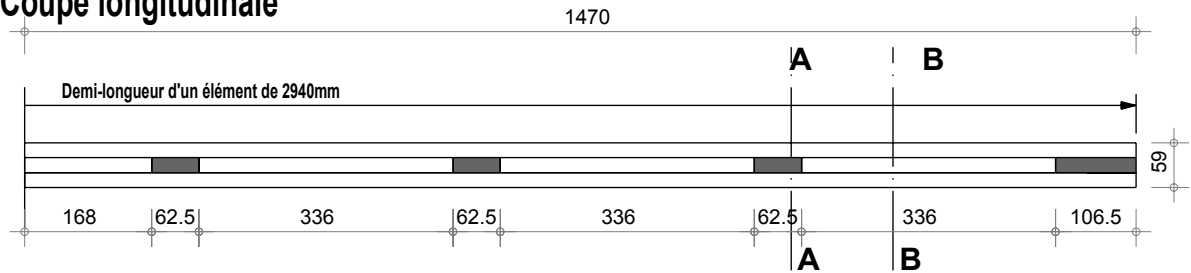

LIGNOTREND Produktions GmbH
Landstrasse 25 D-79809 Weilheim-Bannholz
Tel : 07755-9200 0 Fax : 07755-9200 55

LIGNO TREND®
Ainsi construit notre génération.

Projet	LIGNOTREND U*psi
Plan-Nr. U F - 07	LIGNO U*psi Type F 240 / F360 Coupe de principe

erstellt	Größe	Maßstab	geändert	geändert	geändert
17-10-2007 / AF	A4	1:10			

Upsi et Sesi.2d

Entretoise U*psi - Type T 240 / T 360

Type T 2940-360 / 59 / 100 - 60

Coupe A-A

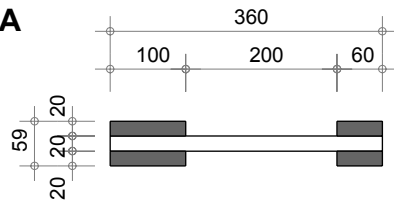

Coupe B-B

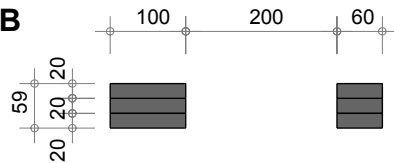

Type T 2940-240 / 59 / 100 - 60

Coupe A-A

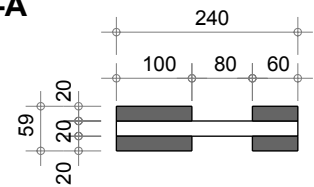

Coupe B-B

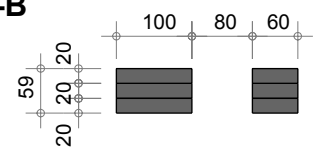

Coupe longitudinale

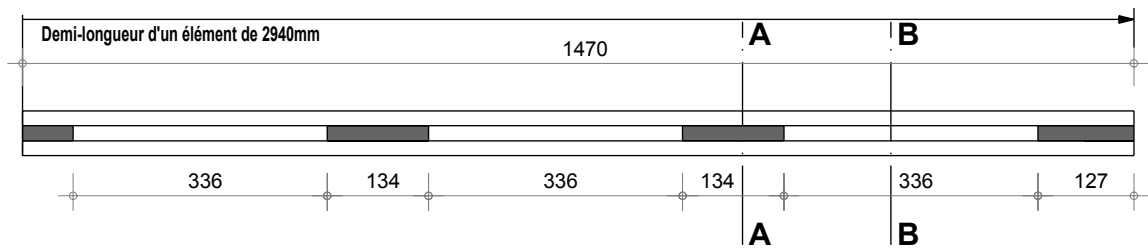

LIGNOTREND Produktions GmbH
Landstrasse 25 D-79809 Weilheim-Bannholz
Tel : 07755-9200 0 Fax : 07755-9200 55

LIGNO TREND®
Ainsi construit notre génération.

Projet	LIGNOTREND U*psi
Plan-Nr. U T - 03	LIGNO U*psi Type T 240 / T 360 Coupe de principe

erstellt	Größe	Maßstab	geändert	geändert	geändert
17-10-2007 / AF	A4	1:10			

Upsi et Sesi.2d

Entretoise U*psi - Type T 300

Type T 2940-300 / 59 / 100 - 60

Coupe A-A

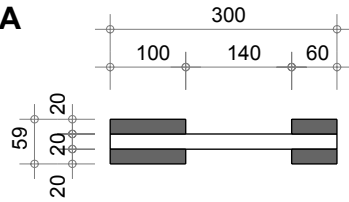

Coupe B-B

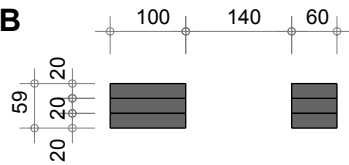

Coupe longitudinale

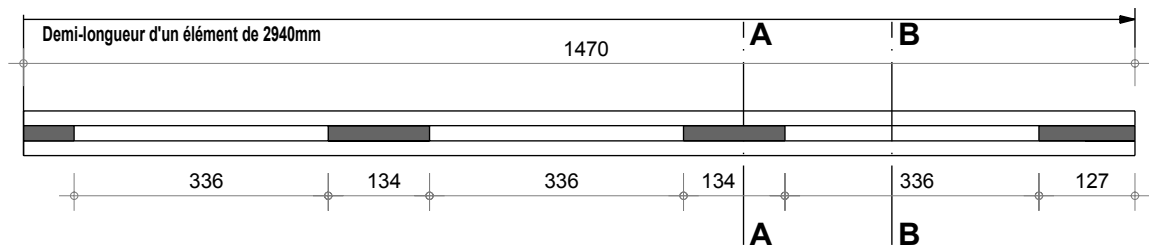

LIGNOTREND Produktions GmbH
Landstrasse 25 D-79809 Weilheim-Bannholz
Tel : 07755-9200 0 Fax : 07755-9200 55

LIGNO ■ TREND®
Ainsi construit notre génération.

Projet LIGNOTREND U*psi

Plan-Nr. LIGNO U*psi Type T 300
U T - 05 Coupe de principe

erstellt	Größe	Maßstab	geändert	geändert	geändert
17-10-2007 / AF	A4	1:10			

Upsi et Sesi.2d

Entretoise U*psi - Type I 120

Type I 2480-120 / 72 / 50

Coupe A-A

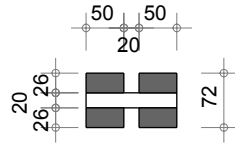

Coupe B-B

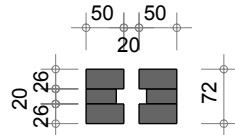

Longueur 2,48 m

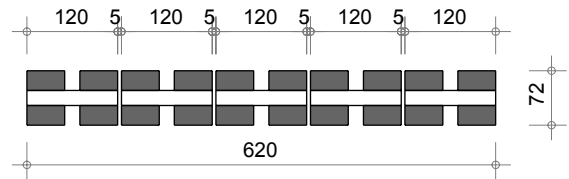

Coupe longitudinale



LIGNOTREND Produktions GmbH
Landstrasse 25 D-79809 Weilheim-Bannholz
Tel : 07755-9200 0 Fax : 07755-9200 55

LIGNO ■ TREND®
Ainsi construit notre génération.

Projet LIGNOTREND U*psi

Plan-Nr. LIGNO U*psi Type I
U I - 02 Coupe de principe

erstellt	Größe	Maßstab	geändert	geändert	geändert
17-10-2007 / AF	A4	1:10			

Upsi et Sesi.2d

LIGNO Se*si

Coupe Transversale Type 60/160

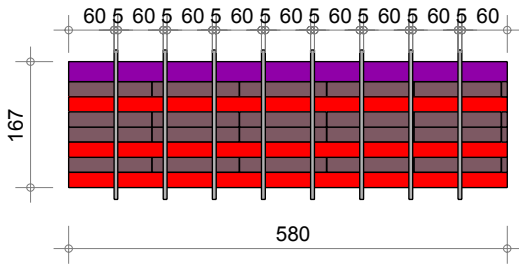

Coupe Transversale Type 120/160

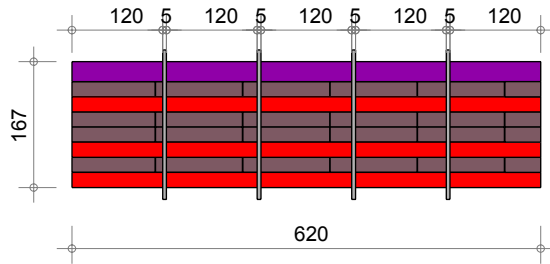

Type 60/100

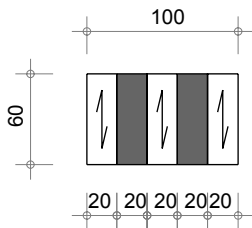

Type 60/120

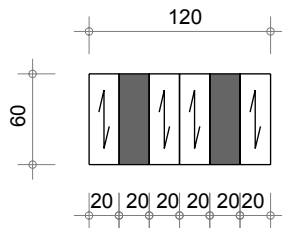

Type 60/140

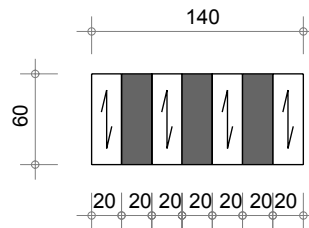

Type 60/160

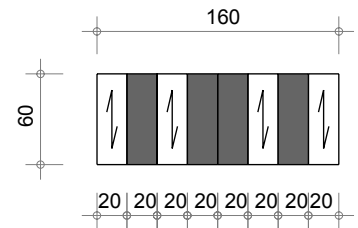

Type 120/100

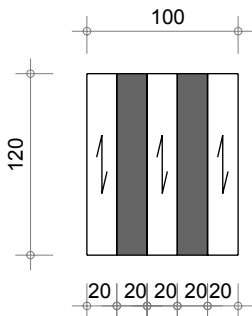

Type 120/120

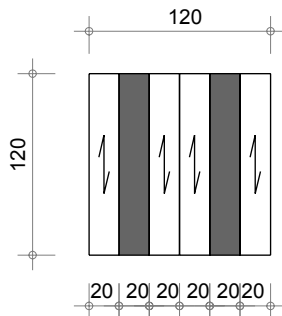

Type 120/140

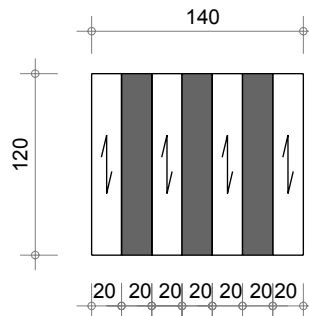

Type 120/160

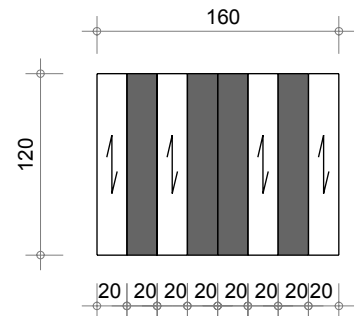

LIGNOTREND Produktions GmbH
Landstrasse 25 D-79809 Weilheim-Bannholz
Tel : 07755-9200 0 Fax : 07755-9200 55

LIGNO TREND®
Ainsi construit notre génération.

Projet LIGNOTREND Se*si

Plan-Nr. LIGNO Se*si
Sesi - 0 Coupe de principe

erstellt	Größe	Maßstab	geändert	geändert	geändert
17-10-2007 / AF	A4	1:10			
Upsi et Sesi.2d					

uni*versa Montant de cloison

Coupe A-A

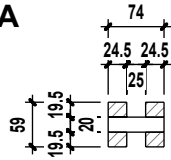

Coupe B-B

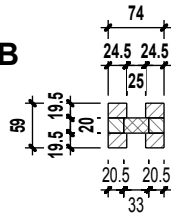

Coupe longitudinale

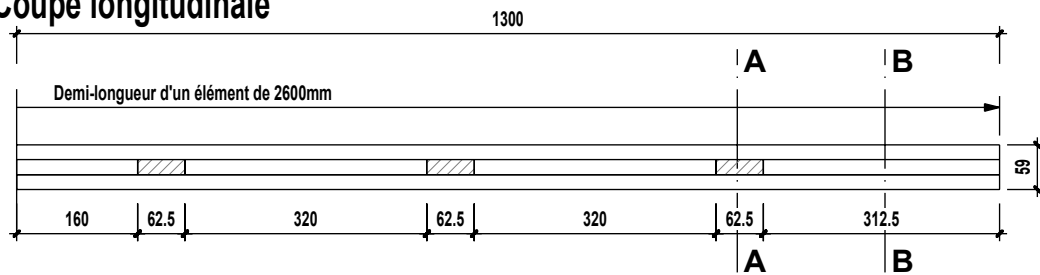

LIGNOTREND Produktions GmbH
Landstrasse 25 D-79809 Weilheim-Bannholz
Tel : 07755-9200 0 Fax : 07755-9200 55

LIGNO ■ TREND®
Ainsi construit notre génération.

Projet	LIGNOTREND
Plan-Nr. 10-01-20	uni*versa Montant de cloison Coupe de principe

erstellt	Größe	Maßstab	geändert	geändert	geändert
01-01-2008 / AF	A4	1:10			

universa Montant de cloison.2d

uni*versa Montant de cloison

1. Raccordement avec profil en U

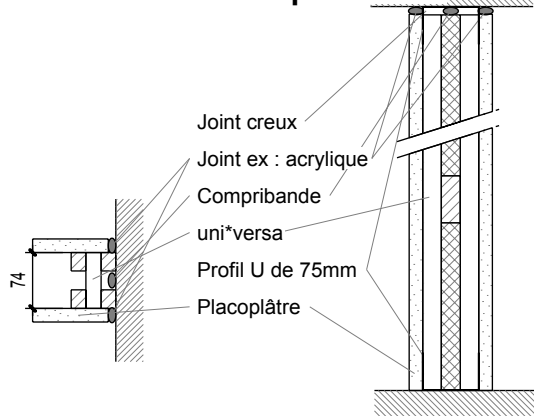

2. Raccordement sur lisses

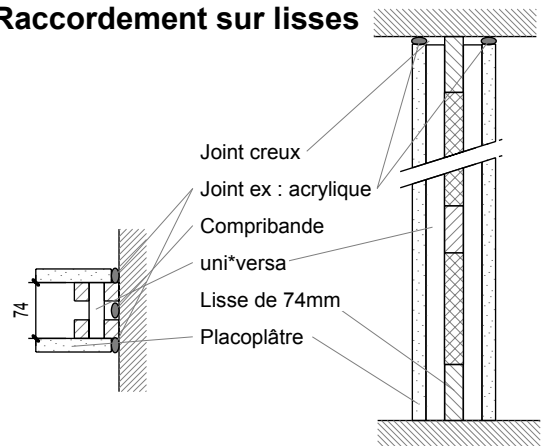

3. Double montant de 125 mm

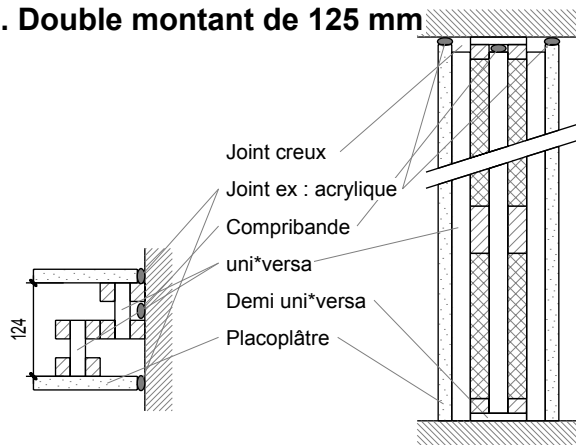

4. Double montant 100mm

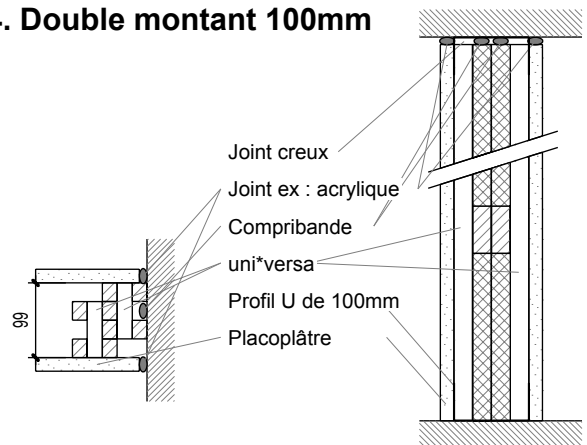

5. Isolation de 25 mm

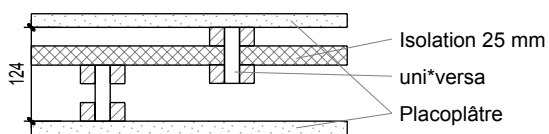

6. Système de raccordement

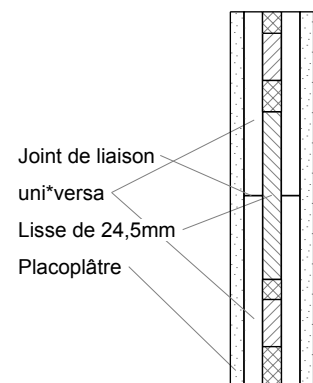

LIGNOTREND Produktions GmbH
Landstrasse 25 D-79809 Weilheim-Bannholz
Tel : 07755-9200 0 Fax : 07755-9200 55

LIGNO TREND®
Ainsi construit notre génération.

Projet

LIGNOTREND

Plan-Nr.
10-01-21

uni*versa Montant de cloison
Coupe de principe

erstellt	Größe	Maßstab	geändert	geändert	geändert
01-01-2008 / AF	A4	1:10			

universa Montant de cloison.2d

Ligno Light alpha

Coupe transversale ech. 1:10

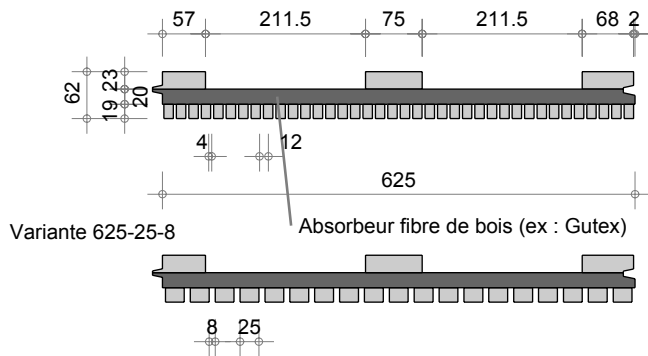

Coupe longitudinale ech. 1:10

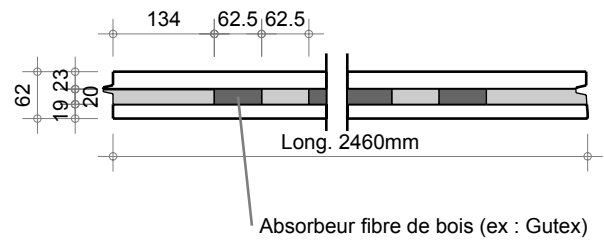

Détail de montage sous dalle ech. 1:7

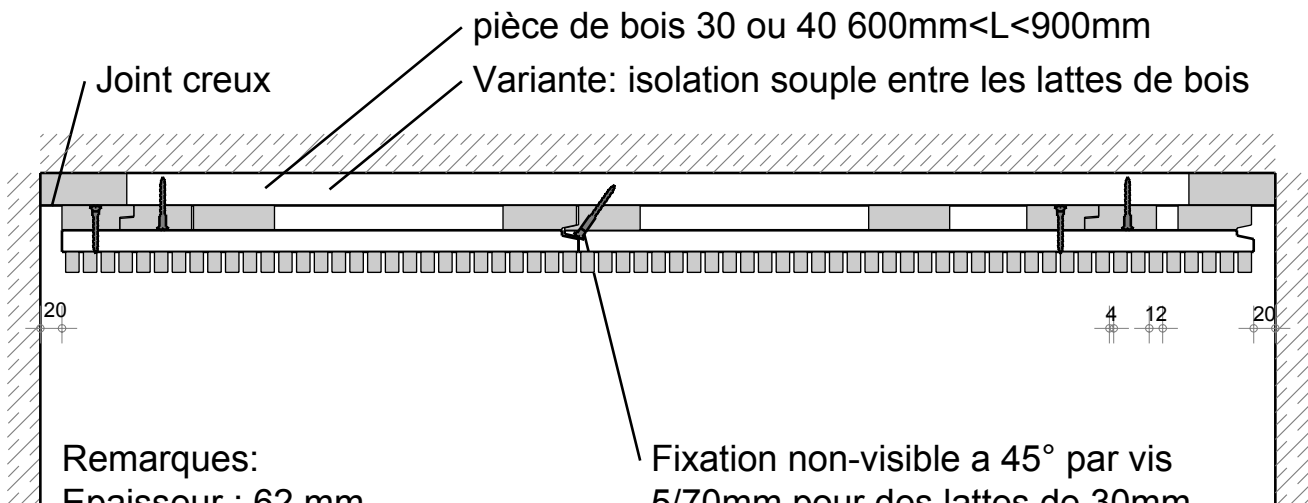

Remarques:

Epaisseur : 62 mm

Largeur : 625 mm

Longueur standard : 2460 mm

Poids: 15.7 Kg/m²

Assemblage rainure et languette en périphérie

Fixation non-visible a 45° par vis
5/70mm pour des lattes de 30mm
5/80mm pour des lattes de 40mm
distance entre vis: 60cm<e<90cm

Taquets de fixations invisibles ech 1:5

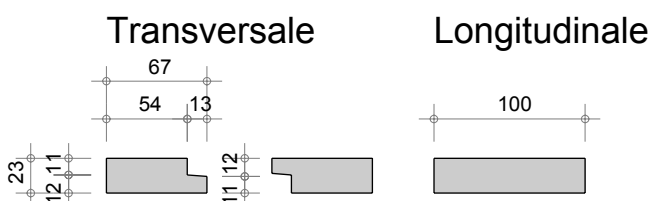

LIGNOTREND Produktions GmbH
Landstrasse 25 D-79809 Weilheim-Bannholz
Tel : 07755-9200 0 Fax : 07755-9200 55

LIGNO TREND®
Ainsi construit notre génération.

Projet	LIGNOTREND				
Plan-Nr.	Ligno Light alpha				
06-01-20	Coupe de principe				
erstellt	Größe	Maßstab	geändert	geändert	geändert
01-01-2008 / AF	A4	1:10			
Light alpha.2d					

Parement de façade

Coupe transversale M 1:5

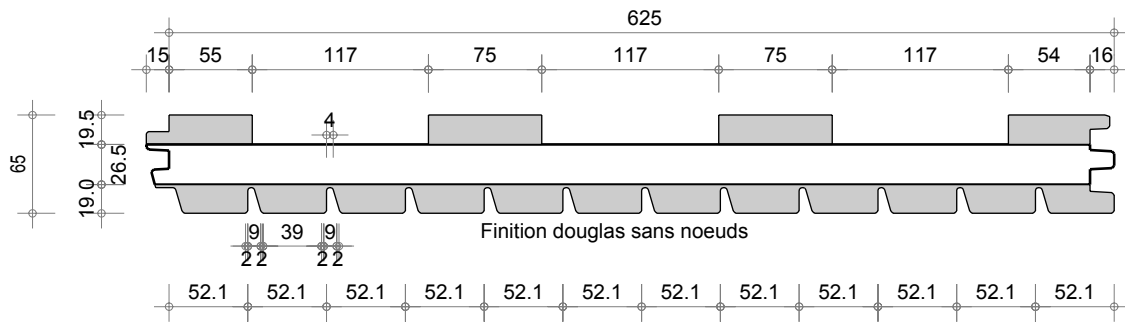

Coupe longitudinale M 1:5

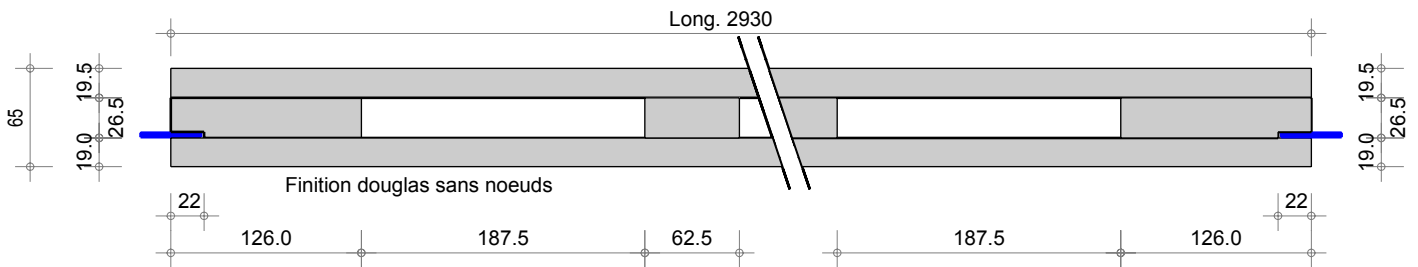

Pièce de liaison M 1:2

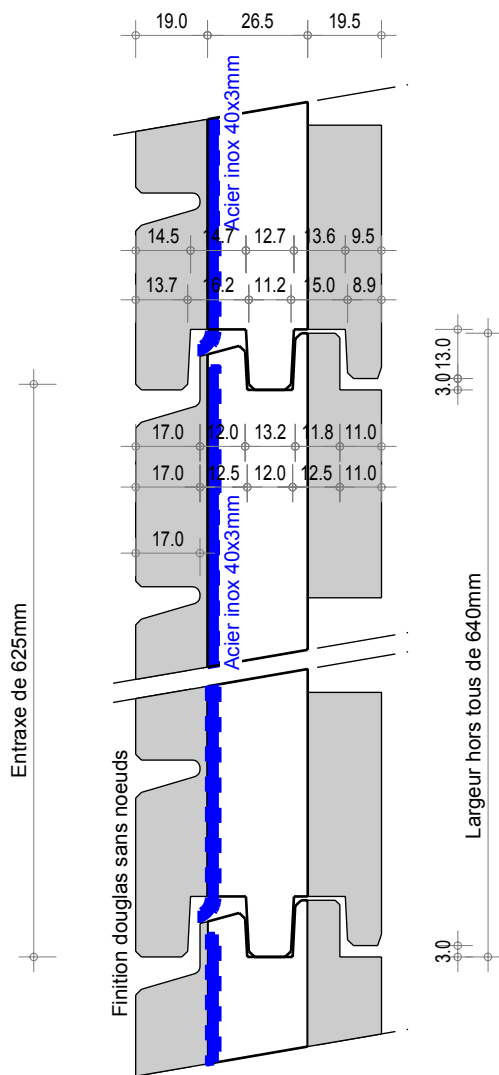

Fixation M 1:2

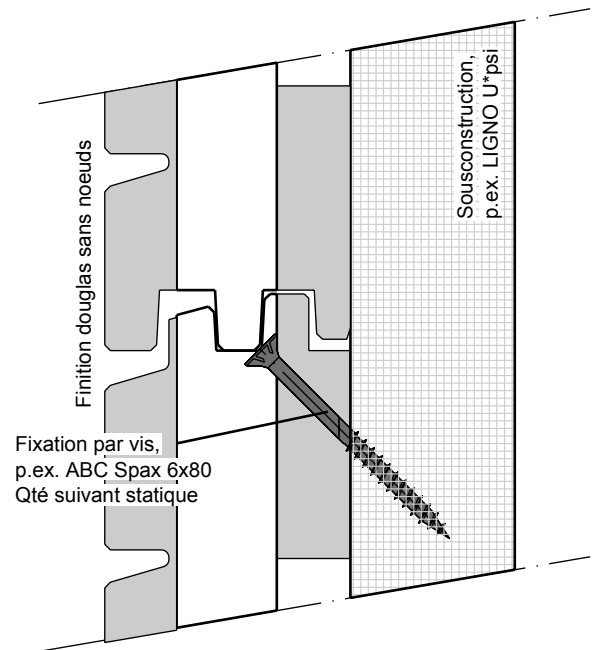

LIGNOTREND Produktions GmbH
 Landstrasse 25 D-79809 Weilheim-Bannholz
 Tel : 07755-9200 0 Fax : 07755-9200 55

LIGNO TREND®
 Ainsi construit notre génération.

Projet LIGNOTREND

Plan-Nr. Parement de façade
 09-01-20 Standard

erstellt	Größe	Maßstab	geändert	geändert	geändert
01-01-2008 / AF	A4	1:10			

Façade 2008.2d